

UP KIT Solution Specification

- ◇ PRELIMINARY SPECIFICATION
- ◆ APPROVED SPECIFICATION

Part Number: KIT-QP070WSVGATLDUOD

Description: 7" KIT SOLUTION WITH TFT LCD (TN Type 300CD, LVDS interface, 1024x600) assemble Pcap (1.8mm Black USB) DRIVEN BY eDP CONVERTER

BOARD AND CABLES

Prepared by: Joy

Confidential

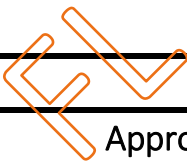
	
Approved by	
Date	

Revision History

Version	Date	Page	Description	Note
V0.1	2018/04/24		First Edition	
V0.2	2018/07/06	14	Modify block diagram	

Confidential



Table of Content

UP KIT Solution Specification	1
A. LCD specification.....	4
1. GENERAL DESCRIPTION	4
1.1 Description.....	4
1.2 Product Summary	4
2. ABSOLUTE MAXIMUM RATING.....	5
2.1 Electrical Absolute Rating	5
2.2 Environment Absolute Rating	5
3. ELECTRICAL CHARACTERISTICS.....	6
3.1 LCM.....	6
3.2 Backlight Unit	6
4. SIGNAL CHARACTERISTICS	7
4.1 Interface Timing.....	7
4.1.1 Timing Characteristics:	7
4.1.2 AC Electrical Characteristics.....	8
4.1.3 DC Electrical Characteristics.....	9
4.1.4 Power ON/OFF Sequence	10
4.2 Pixel Format Image	11
5. INTERFACE PIN DESCRIPTION	12
5.1 LCM Interface PIN Assignment.....	12
6. BLOCK DIAGRAM.....	14
7. OPTICAL CHARACTERISTIC	15
B. Touch Screen specification	18
1. Enviromental Specification	18
2. Mechanical Specification.....	18
3. USB Type Controller	18
C. DIMENSION AND DRAWING.....	19
D. PRECAUTION AND PRODUCT HANDLING	21

Confidential

FL

A. LCD specification

1. GENERAL DESCRIPTION

1.1 Description

7" is a Color Active Matrix Liquid Crystal Display Module composed of a TFT LCD panel and LED backlight system. The screen format is intended to support the WSVGA, 1024x600 screen and 16.7M colors.

1.2 Product Summary

The following items are summary on the table under Ta=25 °C condition:

No.	Item	Specification	Unit
1	Display Size	7	Inch
2	Pixel Number	1024 (H) x RGB x 600 (V)	Pixels
3	Outline Dimension	179 (H) × 118 (V) × 7.85 (D)	mm
4	Active Area	154.214 (H) × 85.92 (V)	mm
5	Display Colors	16.7M	--
6	Pixel Arrangement	RGB vertical stripe	--
7	Display Mode	TN / Normally White / Transmissive	--
8	Electrical Interface	LVDS	--
9	Surface Treatment	Anti-Glare	--
10	Brightness	300 (Typ.)	cd/m ²
11	Contrast Ratio	700 (Typ.)	--
12	Operating Temperature	-20 ~ 70	°C
13	Storage Temperature	-30 ~ 80	°C

2. ABSOLUTE MAXIMUM RATING

2.1 Electrical Absolute Rating

Item	Symbol	Values		Unit	Note
		Min	Max.		
Power supply voltage	VDD	-0.3	5.0	V	
	AVDD	6.5	13.5	V	
	VGH	-0.3	42	V	
	VGL	-20	0.3	V	

Note: If Ta below 50°C , the max. humidity is 90%RH, if Ta over 50°C , absolute humidity should be less than 60%RH.

Note: The response time will be extremely slow when the operating temperature is around -10°C and the back ground will become darker at high temperature operating.

2.2 Environment Absolute Rating

Item	Symbol	Values			Unit	Note
		Min	Typ	Max.		
Operating Temperature	Top	-20		70	°C	Ta=25°C
Storage Temperature	Tstg	-30		80	°C	

Note Typ. VCOM is only a reference value, it must be optimized according to each LCM. Be sure to use VR.



3. ELECTRICAL CHARACTERISTICS

3.1 LCM

Parameter	Symbol	Value			Unit	Note
		Min.	Typ.	Max.		
Supply Voltage	VDD	3.0	3.3	3.6	V	
	AVDD	10.8	11	11.2	V	
	VGH	19.7	20	20.3	V	
	VGL	-6.5	-6.8	-7.1	V	
	VCOM	3.3	3.8	4.3	V	
Input logic high voltage	VIH	0.7VDD	-	VDD	V	
Input logic low voltage	VIL	0	-	0.3VDD	V	

Note Typ. VCOM is only a reference value, it must be optimized according to each LCM. Be sure to use VR.

3.2 Backlight Unit

Item	Symbol	Condition	Min	Typ	Max	Unit
Forward Voltage	VF	Ta=25 °C, IF=20mA/LED		9.6		V
Forward Current	IF	Ta=25 °C, VF=3.2V/LED	-	200	-	mA
Power dissipation	PD		-	1920	-	mW
Uniformity	Avg		-	75	-	%
LED working life(25°C)	-		-	40000	-	Hrs
Drive method	Constant current					
LED Configuration	30 white LEDs (3 LEDs in string and 10 groups in parallel)					

Note1 : Led life time defined as follows: The final brightness is at 50% of original brightness.

The environmental conducted under ambient air flow, at Ta=25±2 °C,60%RH±5%, Typical operating life time is estimated data, led power dissipation is evaluated by led supplier

4. SIGNAL CHARACTERISTICS

4.1 Interface Timing

4.1.1 Timing Characteristics:

Signal	Item	Symbol	Min.	Typ.	Max.	Unit	Note
Clock	Frequency	FxCLK	40.8	51.2	67.2	MHZ	
Vertical Display Term	Total	Tv	610	635	800	Th	Tv=Tvd+Tvb
	Display	Tvd	-	600	-	Th	-
	Blank	Tvb	10	35	200	Th	-
Horizontal Display Term	Total	Th	1114	1344	1400	DCLK	Th=Thd+Thb
	Display	Thd	-	1024	-	DCLK	-
	Blank	Thb	90	320	376	DCLK	-

6 bit LVDS Input

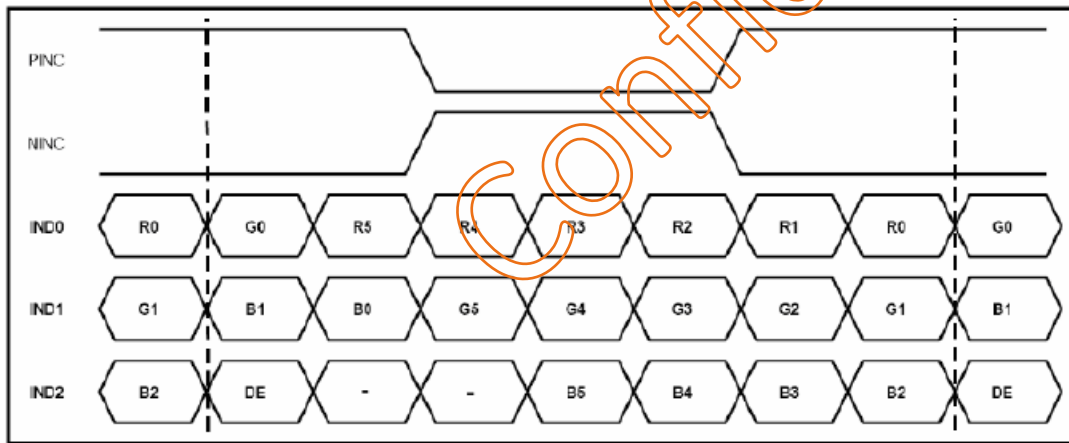

8 bit LVDS Input

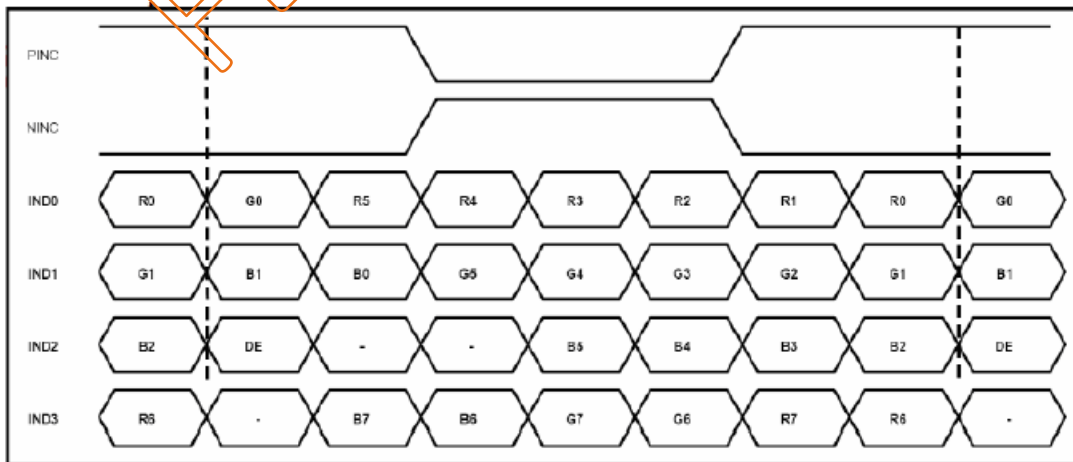

Note; Support DE timing mode only

4.1.2 AC Electrical Characteristics

Item	Symbol	Min.	Typ.	Max.	Unit
Clock Frequency	F _{XCLK}	40.8	51.2	67.2	MHZ
Input data skew margin	T _{RSKM}	500	-	-	ps
Clock high time	T _{VCH}	-	4/(7*F _{XCLK})	-	ns
Clock low time	T _{VCL}	-	3/(7*F _{XCLK})	-	ns

Input clock and data timing diagram

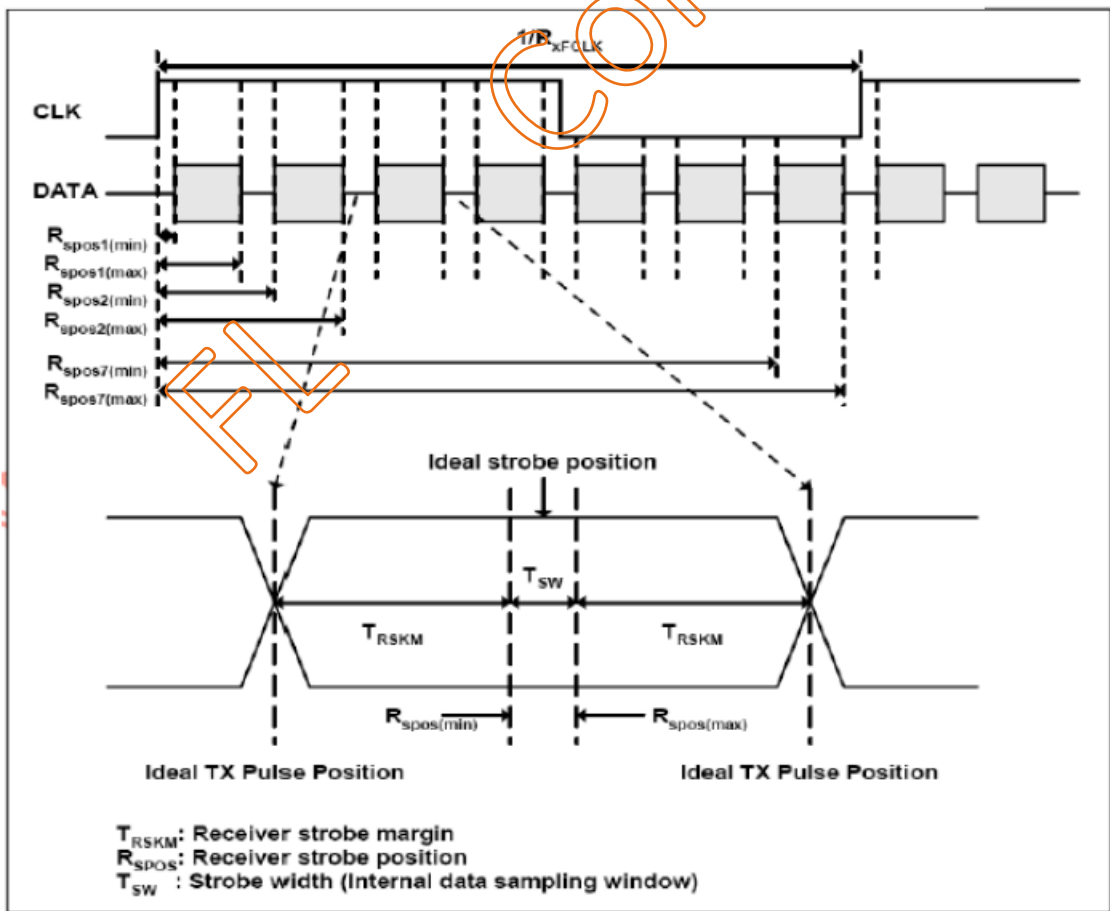
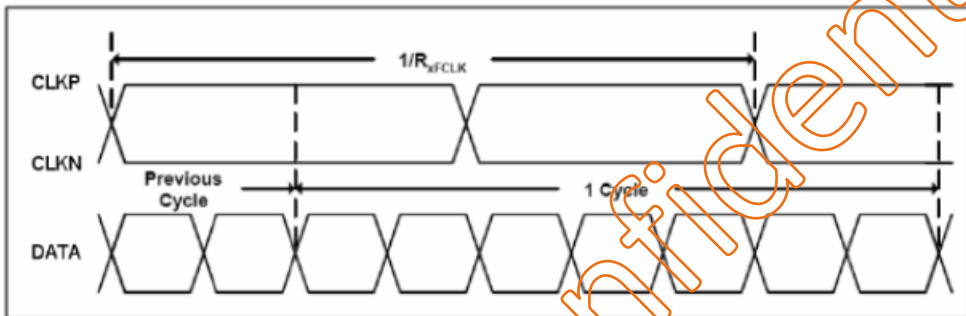

4.1.3 DC Electrical Characteristics

Item	Symbol	Min.	Typ.	Max.	Unit
Differential input high Threshold voltage	RxVTH	-	-	+0.1	V
Differential input low Threshold voltage	RxVTL	-0.1	-	-	V
Input voltage range (single-end)	RxVIN	0	-	2.4	V
Differential input common mode voltage	RxVCM	$ V_{ID} /2$	-	$2.4 - V_{ID} /2$	V
Differential voltage	$ V_{ID} $	0.2	-	0.6	V
Differential input leakage current	RVxliz	-10	-	+10	μ A

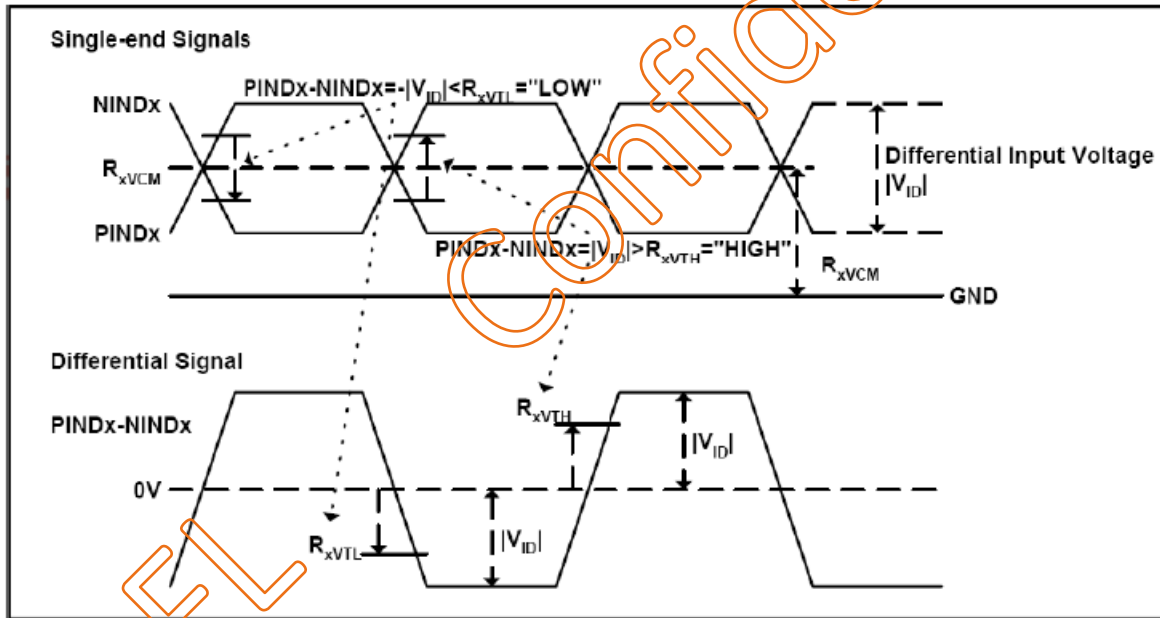

4.1.4 Power ON/OFF Sequence

Power ON

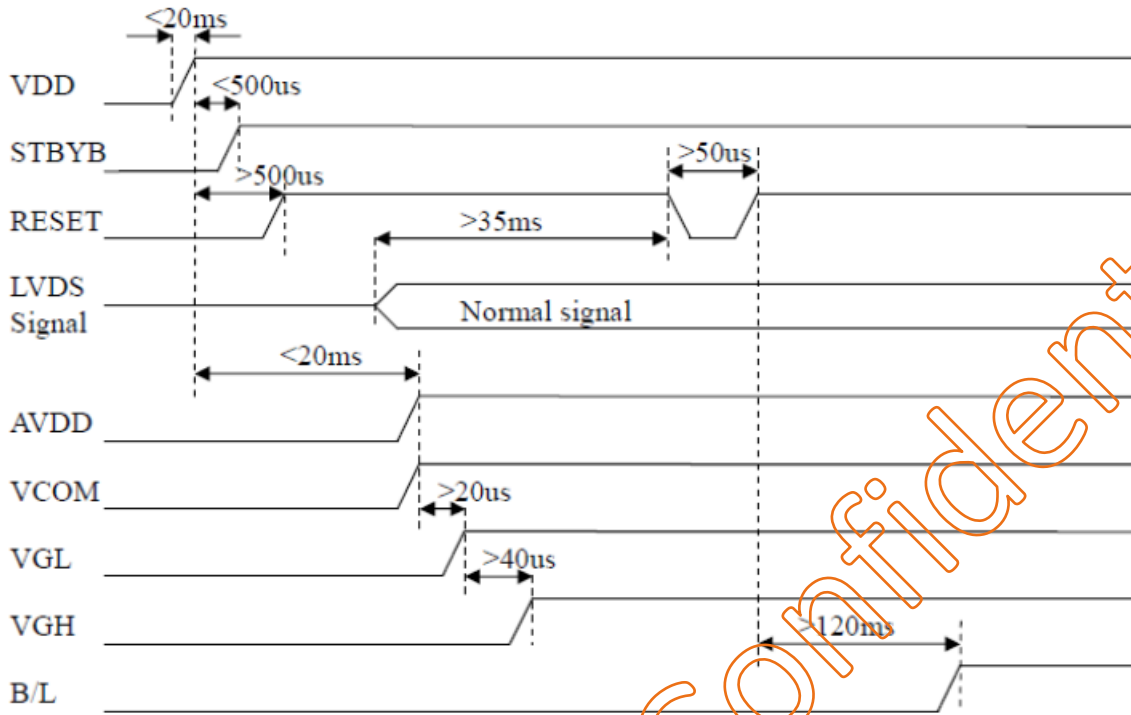

Power OFF

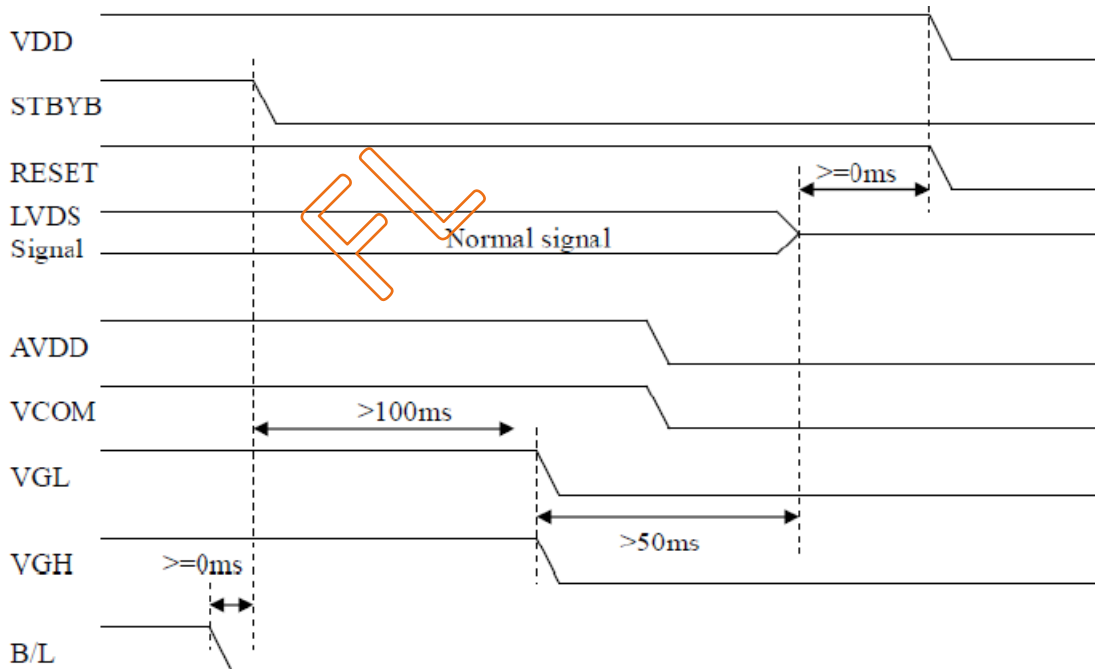

4.2 Pixel Format Image

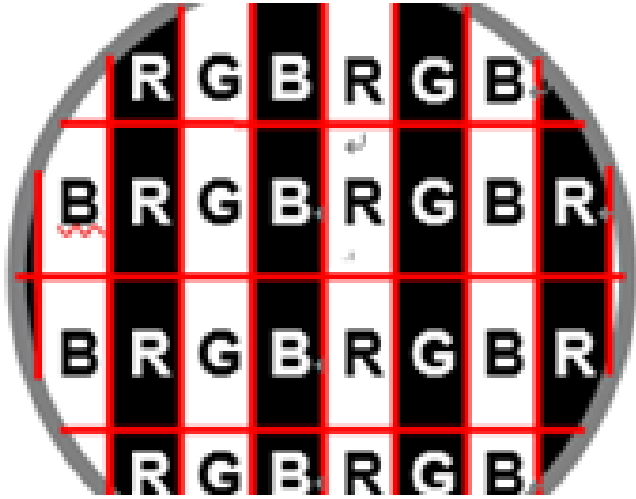

Confidential



5. INTERFACE PIN DESCRIPTION

5.1 LCM Interface PIN Assignment

	Symbol	Description	Note
1	VCOM	Common Voltage	-
2	VDD	Power supply	-
3	VDD	Power supply	-
4	NC	No connection	-
5	RESET	Global reset pin	-
6	STBYB	Standby mode, Normally pulled high STBYB=1, normal operation STBYB=0, timing controller, source driver will turn off, all output are High-Z	-
7	GND	Ground	-
8	RXIN0-	LVDS Differential Data Input (Negative)	-
9	RXIN0+	LVDS Differential Data Input (Positive)	-
10	GND	Ground	-
11	RXIN1--	LVDS Differential Data Input (Negative)	-
12	RXIN1+	LVDS Differential Data Input (Positive)	-
13	GND	Ground	-
14	RXIN2-	LVDS Differential Data (Negative)	-
15	RXIN2+	LVDS Differential Data (Positive)	-
16	GND	Ground	-
17	CLKIN-	LVDS Differential Clock (Negative)	-
18	CLKIN+	LVDS Differential Clock (Positive)	-
19	GND	Ground	-
20	RXIN3-	LVDS Differential Data Input (Negative)	-
21	RXIN3+	LVDS Differential Data Input (Positive)	-
22	GND	Ground	-
23	NC	No connection	-
24	NC	No connection	-
25	GND	Ground	-
26	NC	No connection	-
27	DIMO	Backlight CABc controller signal output	-
28	SELB	6bit/8bit mode select	(1)
29	AVDD	Power for analog circuit	-
30	GND	Ground	-
31	LED-	LED Cathode	-
32	LED-	LED Cathode	-
33	L/R	Horizontal Inversion	(3)
34	U/D	Vertical inversion	(3)
35	VGL	Gate OFF voltage	-

36	CABCEN1	CABC HW enable	(2)
37	CABCEN0	CABC HW enable	(2)
38	VGH	Gate ON voltage	-
39	LED+	LED Anode	-
40	LED+	LED Anode	-

Note (1) If LVDS input data is 6-bit, SELB must be set to High

If LVDS input data is 8-bit, SELB must be set to Low.

Note (2) When CABC_EN=00, CABC OFF

When CABC_EN=01, user interface image

When CABC_EN=10, still picture

When CABC_EN=11, moving image

Note (3) When L/R=0, set right to left scan direction

When L/R=1, set left to right scan direction

When U/D=0, set top to bottom scan direction

When U/D=1, set bottom to top scan direction

Confidential



6. BLOCK DIAGRAM

The following diagram shows the functional block of the TFT module:

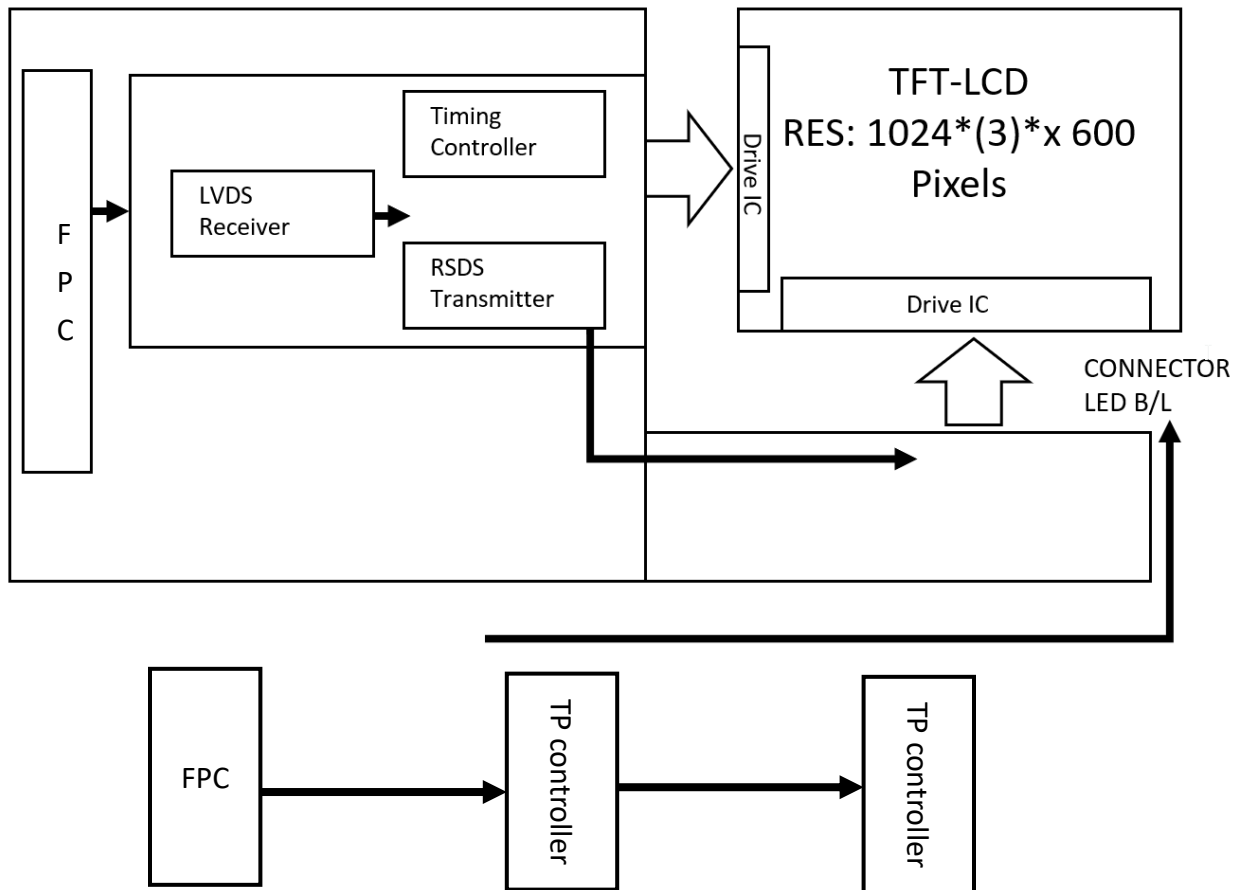

7. OPTICAL CHARACTERISTIC

The optical characteristics are measured under stable conditions at room temperature.

Item		Symbol	Condition	Min.	Typ.	Max.	Unit	Note
Contrast Ratio		CR	$\theta_x=0^\circ, \theta_y=0^\circ$ Viewing angle at normal direction	500	700		-	(2)(5)(6)
Response Time		TR+TF		-	25	50	ms	(3)
NTSC Ratio				45	50		%	
Center Luminance of White		L_c		240	300	-	cd/m ²	(4)(5)
Chromaticity	Red	R_x		$\theta_x=0^\circ, \theta_y=0^\circ$ Viewing angle at normal direction	Typ.	Typ.	+0.05	
		R_y						
	Green	G_x						
		G_y						
	Blue	B_x						
		B_y						
	White	W_x						
		W_y						
Viewing Angle	Horizontal	θ_{x+}	70	75	-	Deg.	(1)(5)	
		θ_{x-}	70	70	-			
	Vertical	θ_{y+}	60	75	-			
		θ_{y-}	60	50	-			

The following optical specifications shall be measured in a darkroom or equivalent state (ambient luminance <2 lux, and at room temperature).

The room temperature is 25°C±2°C

Note 1: Definition of Viewing Angle

Viewing angle is the angle at which the contrast ratio is greater than 10. The viewing angles are determined for the horizontal or the vertical clock direction with respect to the optical axis which is normal to the LCD surface

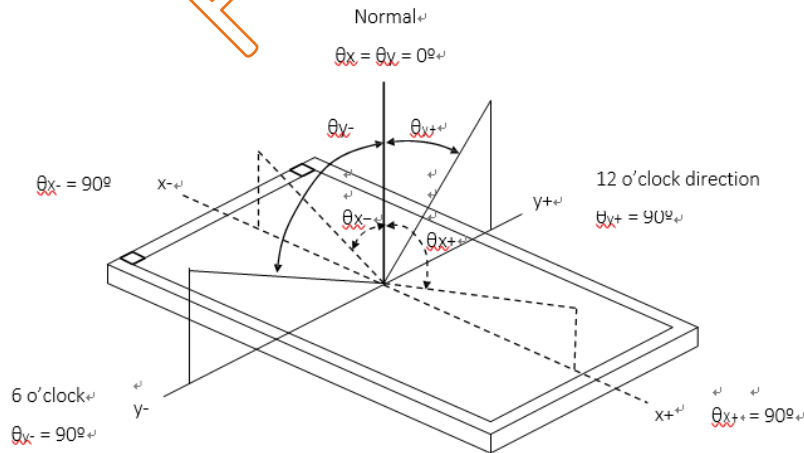

Note 2: Definition of Contrast Ratio (CR)

Measure the viewing angle of $\Theta = 0$ and at the center of the LCD surface. Luminance with all pixels in white state divide by Luminance with all pixels in Black state

Note 3 Definition of Response Time:

The response time is set initially by defining the “Rising Time (T_r)” and the “Falling Time (T_f)” respectively. The response time interval is between 10% and 90% of amplitudes, please refer the figure to the followings:

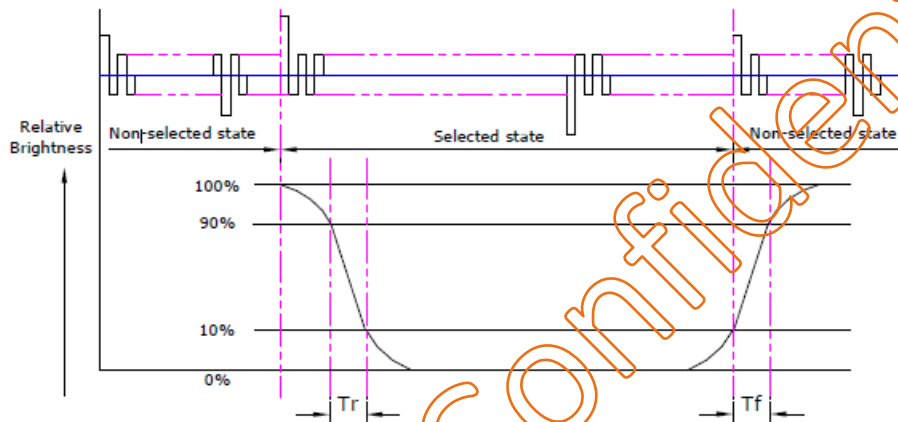

Note 4: Definition of Brightness (L_c)

Measure the center area of the panel and the viewing angle of the $\theta_x = \theta_y = 0^\circ$

Note 5: The method of optical measurement:

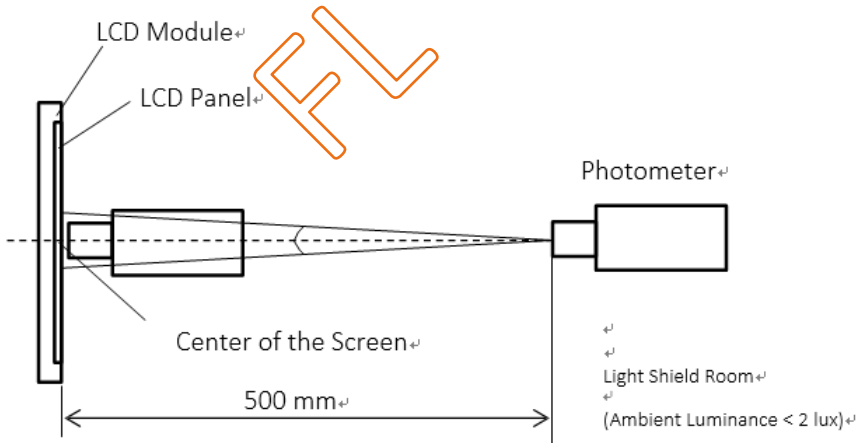

Note 6: Definition of White Variation (δW):

Measure the luminance of gray level 255 at 9 points

$$\delta W = \text{Maximum [L (1), L (2), L (3)...L (8), L (9)]} / \text{Minimum [L (1), L (2), L (3)... L (4), L (5)]}$$

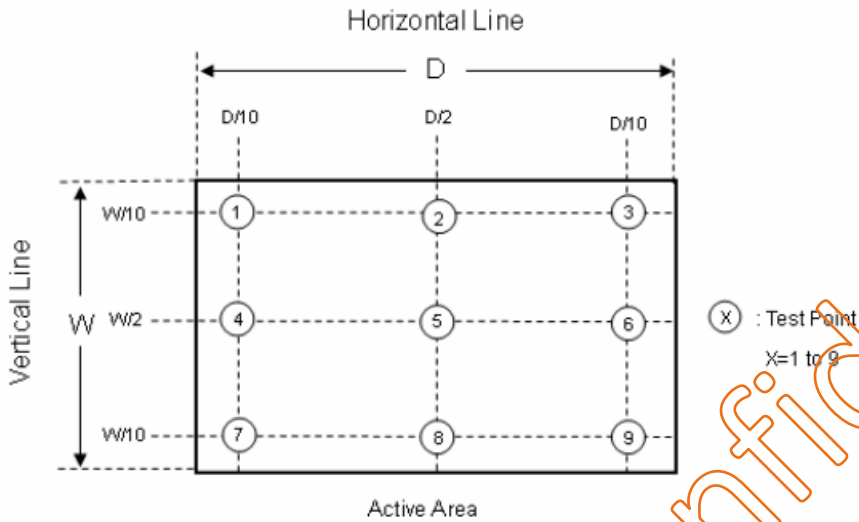

Confidential

FL

B. Touch Screen specification

1. Environmental Specification

Specification	Value	Remarks
Operating Temperature	-20°C ~ 70°C	
Storage Temperature	-30°C ~ 80°C	
Operating Humidity	20%~90%RH	
Storage Humidity	10%~90%RH	

2. Mechanical Specification

Specification	Value
Operating Life (Finger input)	10 ⁷ times
Light Transmittance	85% Min. (JIS K-7105) with glass
Surface hardness	6H
FPC Peeling Force	5N Max

3. USB Type Controller

Parameters	Features
Circuit Board Dimension	Refer to drawings
Channels of Panel	Based on Sensor Design
Input Voltage	5V for USB
Linearity(Note 1)	Single Line drawing accuracy : Up to 1pt +/- 1mm offset /10mm
	Single Touch (point) accuracy : Up to 1pt +/- 1mm
Interface	USB: 1.1 Full Speed
Resolution	4096×4096 resolution
Power consumption(mA)	Active Mode: <50mA
	Idle Mode : <45mA
	Sleep Mode :< 15mA
	(Operation Mode :Active Mode only)
Report rate(points/sec) Note(2)	> 100 Hz
Response time	Average < 25 ms

Note (1): Depending by Sensor design and other parameters, Refer to Windows 8 Logo regulation if need to follow min spec

Note (2): Report rate will vary by channel number, cover thickness, number of fingers and other parameters

C. DIMENSION AND DRAWING

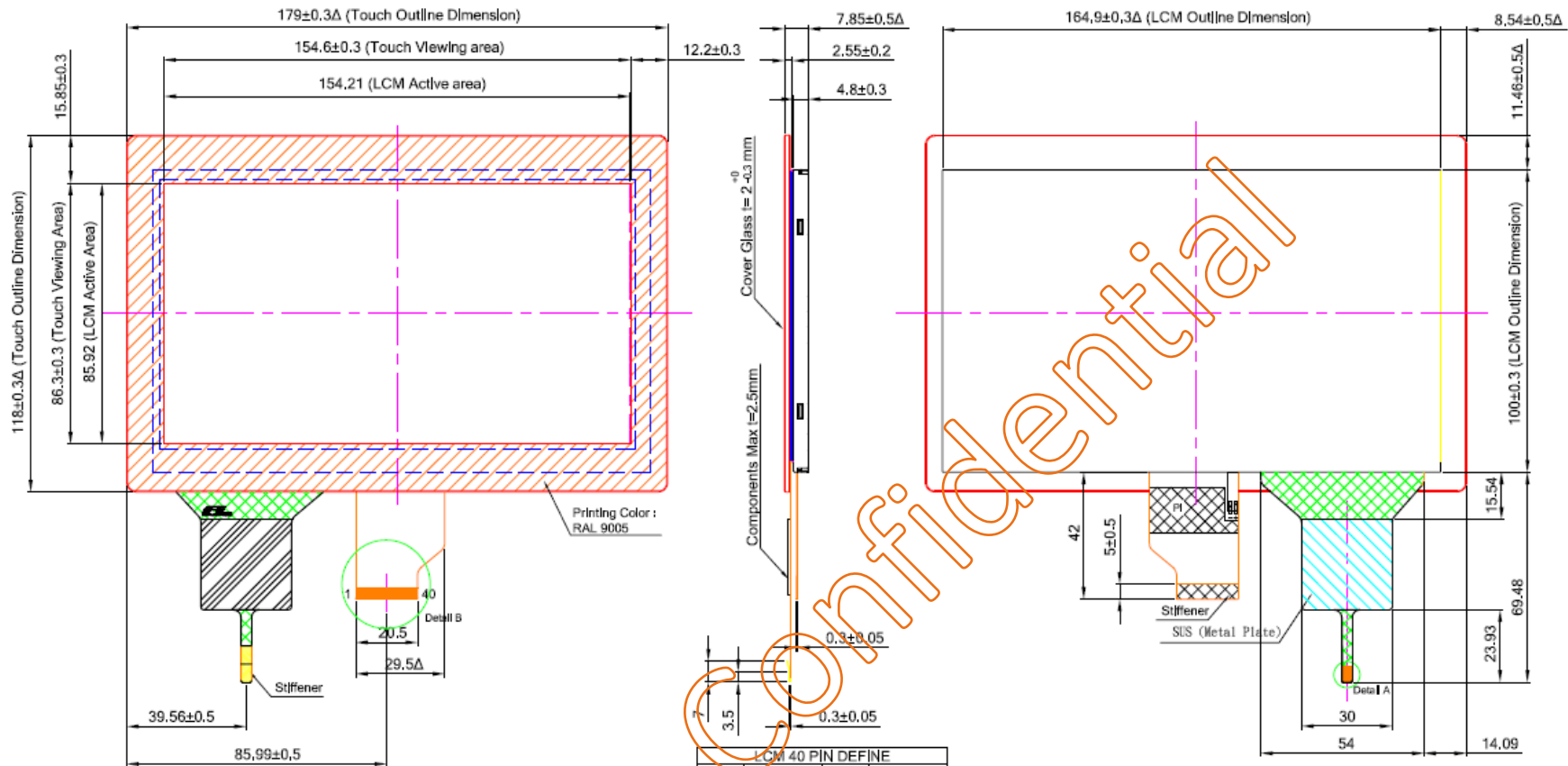

Confidential

LCM 40 PIN DEFINE			
PIN	SYMBOL	PIN	SYMBOL
1	VCOM	21	RXIN3+
2	VDD	22	GND
3	VDD	23	NC
4	NC	24	NC
5	RESET	25	GND
6	STBYB	26	NC
7	GND	27	DIMO
8	RXIN0-	28	SELB
9	RXIN0+	29	AVDD
10	GND	30	GND
11	RXIN1-	31	LED-
12	RXIN1+	32	LED-
13	GND	33	L/R
14	RXIN2-	34	U/D
15	RXIN2+	35	VGL
16	GND	36	CABCEN1
17	RXCLKIN-	37	CABCEN0
18	RXCLKIN+	38	VGH
19	GND	39	LED+
20	RXIN3-	40	LED+

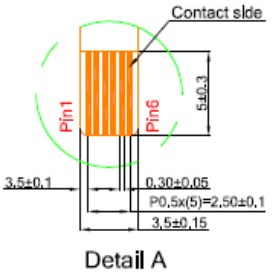

USB Interface Pin Define	
Pin 01	VDD
Pin 02	D-
Pin 03	D+
Pin 04	GND
Pin 05	RST
Pin 06	NC

- NOTES:**
- 1.General tolerance are $\pm 0.3\text{mm}$
 - 2.Brighness: 300(TYP) cd/m^2
 3. Contrast : 800:1(TYP)
 - 4.Power supply voltage : 3.3V
 - 5.ROHS must be compiled
 - 6.Display mode:Transmissive/Normal White/Anti-glare
 7. LCD Solution : QX-070WSVGATLD00D
 8. Touch Solution : FLTP07F18B-C3-000
 9. Assembly Solution : DSA

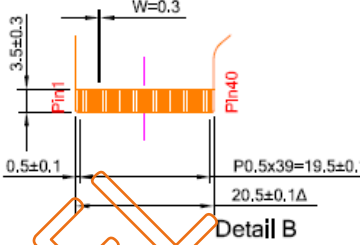

Customer Approval		Part Number		QP-070WSVGATLDU0D
Date	Rev	Date	Process	Description
Outpass				
Notes				
Signature		Date	Design By	Date
		Print Drawing	Route	Check By
				Date
				Approved By



Converter board & Accessory

1. eDP Converter Board
P/N : TFC_UP2EDP-A

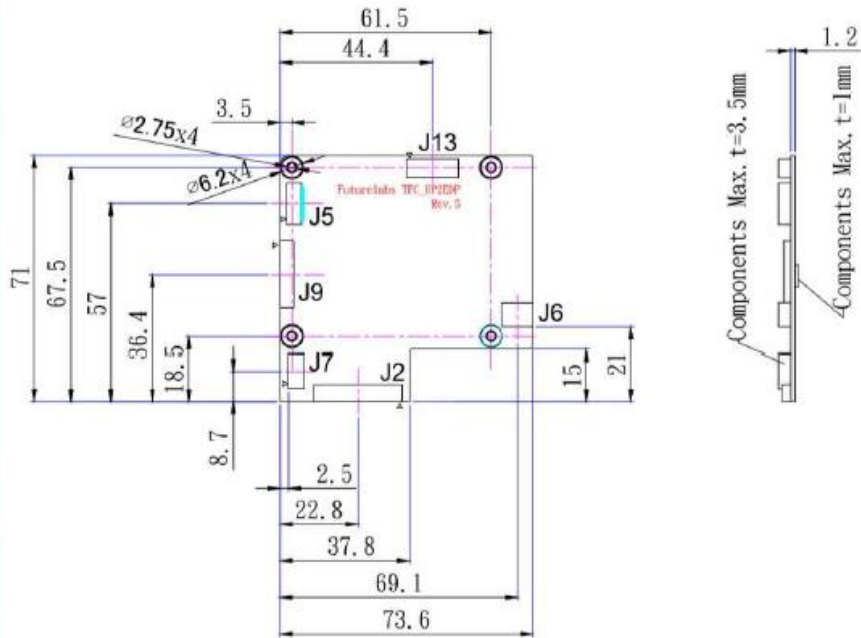

2. eDP to eDP cable
P/N : CBL-30-05-100-A

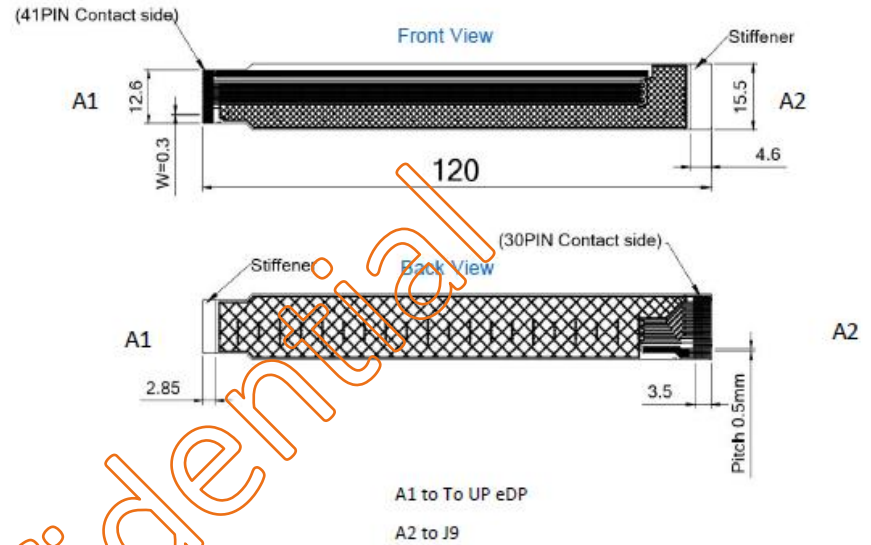

3. USB Cable
P/N : CB_UP2USB8

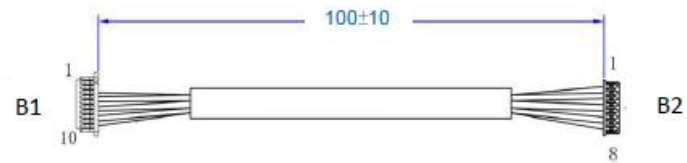

Connector table of eDP Converter Board

Connector Number	Function	Cable
J2	Lvds for 7W	To 7W LCD only
J5	8 pin UB to 10 Pin USB UP	CB_UP2USB8
J6	7"W Touch Controller	To 7W Touch only
J7	USB interface	
J9	eDP to UP Board eDP-DSI	CBL-30-05-100-A
J13	No use	

B1 To to UP USB
B2 To to J5

Customer Approval		Part Number		KIT-QP070WSVGATLDU0D	
Date	Rev. Date	Person	Description		
Company Name					
Signature	Date	Design By	Drawn By	Check By	Approved By
File Drawing					

D. PRECAUTION AND PRODUCT HANDLING

- Do not apply the external force such as bending or twisting to the module during assembly.
- Do not insert and plug out the input connector while the LCD panel is operating.
- Do not take apart the panel or frame from module assembly or insert anything into the backlight unit.
- Do not keep the same pattern in a long period of time, it may cause image sticking on LCD panel. Can use shuffle content periodically if fixed pattern is displayed on the screen.
- Do not touch the display area with bare hands, this will stain the display area.
- Pay attention to handle lead wire of backlight, that is not tugged in connect with LED driver.
- Do not change variable resistance settings in LCD panel, it may cause not satisfy of LCD characteristics specification.
- To avoid the static electricity to damage the CMOS LSI, the operator should be grounded when in contact with the LCD panel, and also to all electrical equipment.
- Need to follow the correct power frequency when LCD panel is connecting and operating, this can avoid damage to CMOS LSI during latch-up.
- Need to store the LCD panel indoor without the exposure of sunlight where the temperature is $25^{\circ}\text{C} \pm 5^{\circ}\text{C}$ and the humidity is below 60% RH.



Distributed by:



The Netherlands



Elektrostraat 17
NL-7483 PG Haaksbergen

T: +31 (0)53 573 33 33
F: +31 (0)53 573 33 30
E: nl@texim-europe.com

Belgium



Zuiderlaan 14 bus 10
B-1731 Zellik

T: +32 (0)2 462 01 00
F: +32 (0)2 462 01 25
E: belgium@texim-europe.com

UK & Ireland



St. Mary's House, Church Lane
Carlton Le Moorland
Lincoln LN5 9HS

T: +44 (0)1522 789 555
F: +44 (0)845 299 22 26
E: uk@texim-europe.com

Germany North



Bahnhofstrasse 92
D-25451 Quickborn

T: +49 (0)4106 627 07-0
F: +49 (0)4106 627 07-20
E: germany@texim-europe.com

Germany South



Martin-Kollar-Strasse 9
D-81829 München

T: +49 (0)89 436 086-0
F: +49 (0)89 436 086-19
E: germany@texim-europe.com

Austria



Warwitzstrasse 9
A-5020 Salzburg

T: +43 (0)662 216 026
F: +43 (0)662 216 026-66
E: austria@texim-europe.com

Nordic region



Sdr. Jagtvej 12
DK-2970 Hørsholm

T: +45 88 20 26 30
F: +45 88 20 26 39
E: nordic@texim-europe.com

Italy



Via Matteotti 43
IT-20864 Agrate Brianza (MB)

T: +39 (0)395 967 226
F: +39 (0)395 967 226
E: italy@texim-europe.com

General information



info@texim-europe.com
www.texim-europe.com