

## UP KIT Solution Specification

- ◇ PRELIMINARY SPECIFICATION
- ◆ APPROVED SPECIFICATION

**Part Number: KIT-156ITL20PUSA2B**

Description: 15.6" KIT SOLUTION with TFT LCD (500CD with LVDS 1366\*768 format) assemble Pcap 3mm Black USB DRIVEN by CONVERTER BOARD and CABLE

Prepared by: Joy

Version : 0.1



Approved by	
Date	

## Revision History

Version	Date	Page	Description	Note
V0.1	2018/4/25		First Edition	

Confidential



## Table of Content

UP KIT Solution Specification .....	1
A. LCD specification.....	4
1. GENERAL DESCRIPTION .....	4
1.1 Description.....	4
1.2 Product Summary .....	4
2. ABSOLUTE MAXIMUM RATING.....	5
2.1 Electrical Absolute Rating .....	5
2.2 Environment Absolute Rating.....	5
3. ELECTRICAL CHARACTERISTICS.....	6
3.1 LCM.....	6
3.2 Backlight Unit .....	8
4. SIGNAL CHARACTERISTICS .....	9
4.1 Interface Timing.....	9
4.1.1 Timing Characteristics: .....	9
4.1.2 Power ON/OFF Sequence .....	11
4.2 Pixel Format Image .....	12
5. INTERFACE PIN DESCRIPTION.....	13
5.1 LCM Connector PIN Assignment.....	13
5.2 Backlight and LED Driver Connector PIN Assignment.....	14
6. BLOCK DIAGRAM.....	15
7. OPTICAL CHARACTERISTIC .....	16
B. Touch Screen specification .....	19
1. Enviromental Specification .....	19
2. Mechanical Specification.....	19
3. USB Type Controller.....	19
C. DIMENSION AND DRAWING.....	20
D. PRECAUTION AND PRODUCT HANDLING .....	22

## A. LCD specification

### 1. GENERAL DESCRIPTION

#### 1.1 Description

15.6" is a Color Active Matrix Liquid Crystal Display Module composed of a TFT LCD panel and LED backlight system. The screen format is intended to support WXGA 1366x768 screen and 16.7M colors.

#### 1.2 Product Summary

The following items are summary on the table under Ta=25 °C condition:

No.	Item	Specification	Unit
1	Display Size	15.6	Inch
2	Pixel Number	1366 (H) x RGB x 768 (V)	Pixels
3	Outline Dimension	363.80 (H) x 215.98 (V) x 9.30 (D)	mm
4	Active Area	344.23 (H) x 193.54 (V)	mm
5	Display Colors	16.7M	--
6	Pixel Arrangement	RGB vertical stripe	--
7	Display Mode	Normally White / Transmissive	--
8	Electrical Interface	LVDS	--
9	Surface Treatment	Anti-Glare, 3H	--
10	Original TFT Brightness	500 (Typ.)	cd/m2
11	Contrast Ratio	600 (Typ.)	--
12	Power Consumption (Typ)	Total 12.1	W
13	Operating Temperature	-10 ~ 60	°C
14	Storage Temperature	-20 ~ 60	°C

## 2. ABSOLUTE MAXIMUM RATING

### 2.1 Electrical Absolute Rating

Item	Symbol	Values			Unit	Note
		Min	Typ	Max		
Power supply voltage	VCC	-0.3	-	6	V	(1)
Logic Input Voltage	VIN	-0.3	-	4	V	
Converter Voltage	LED_Vin	0	12.0	18.0		Duty=100% (1)(2)
Enable Voltage	LED_EN	0	3.3	7	V	
Backlight Adjust	LED_PWM	0	3.3	7	V	Pulse width $\leq$ 10msec. and duty $\leq$ 10%

Note (1) Permanent damage to the device may occur if max values are exceeded. Function operation should be restricted to the conditions described under normal operating conditions.

(2) Specified values are for input pin of LED light bar at Ta=25+/-2°C

### 2.2 Environment Absolute Rating

Item	Symbol	Values			Unit	Note
		Min	Typ	Max.		
Operating Temperature	T <sub>op</sub>	-10		60	°C	Ta=25°C
Storage Temperature	T <sub>stg</sub>	-20		60	°C	

Note (1) Temperature and relative humidity range is shown in the figure below,

- (a) 90% RH Max.. (Ta<40°C)
- (b) Wet-bulb temperature should be 39°C Max. (Ta<40°C)
- (c) No condensation

(2) The temperature of panel surface should be 0°C min. and 65°C max.

### 3. ELECTRICAL CHARACTERISTICS

#### 3.1 LCM

Parameter	Symbol	Value			Unit	Note
		Min.	Typ.	Max.		
Power Supply Voltage	VCC	4.5	5	5.5	V	
Ripple Voltage	VRP	--	--	150	mV	
Rush Current	I <sub>RUSH</sub>	--	--	3.0	A	(2)
Power Supply Current	White	--	0.17	0.22	A	(3)
	Black	--	0.24	0.29	A	
	Vertical Stripe	--	0.27	0.32	A	
Power Consumption	P <sub>LCD</sub>	--	1.35	1.6	W	
LVDS differential input voltage	V <sub>id</sub>	200	--	600	mV	-
LVDS common input voltage	V <sub>ic</sub>	1.0	1.2	1.4	V	-
Terminating Resistor	R <sub>T</sub>		100		Ohm	

Note (1) The assembly should be always operated within above ranges.

T<sub>a</sub> = 25 ± 2 °C

Note (2) Measurement Conditions:

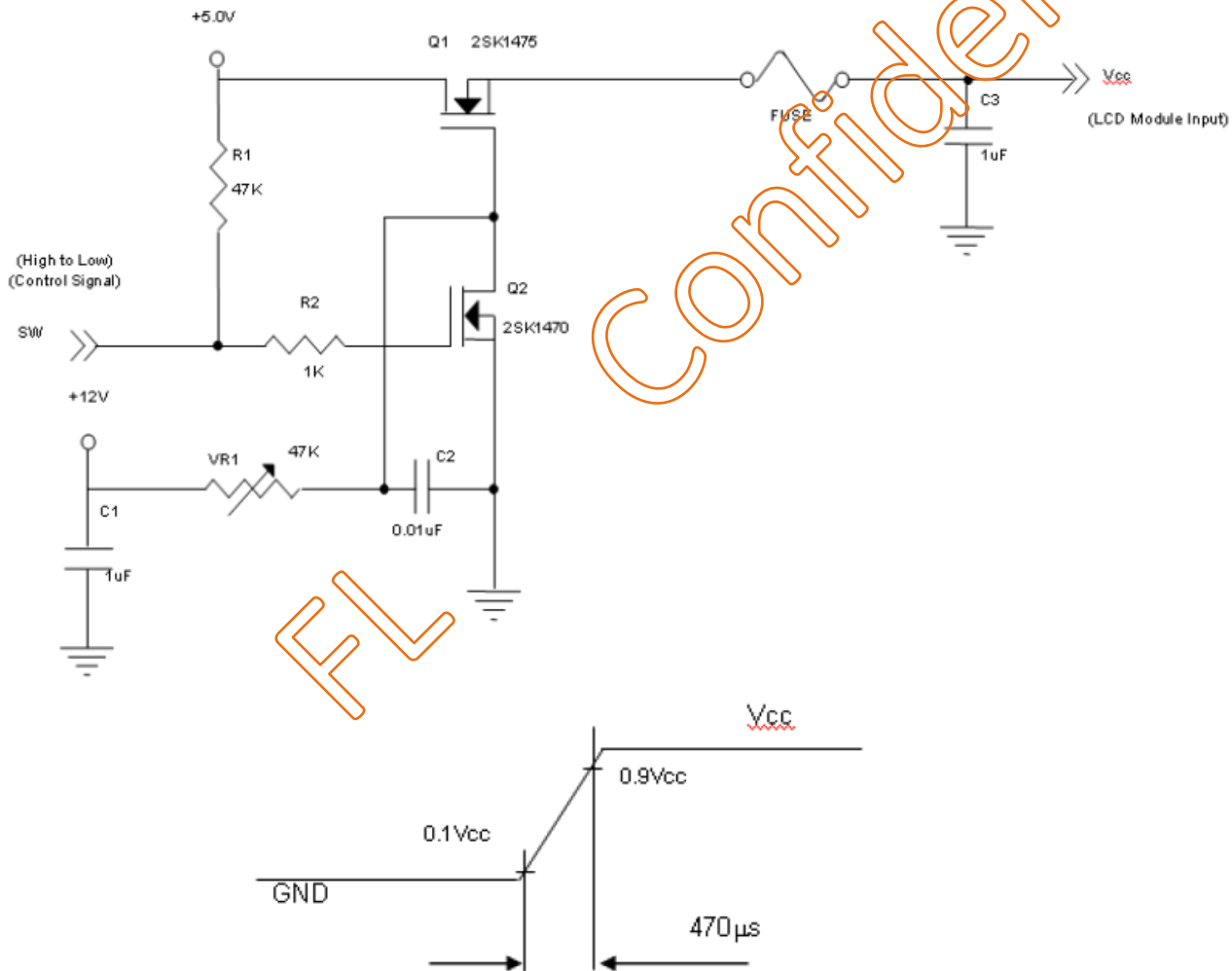

Note (3) The specified power supply current is under the conditions at  $V_{cc}=5V$ ,  $F_r=60Hz$ , whereas a power dissipation check pattern below is displayed

a. White Pattern



Active Area

b. Black Pattern



Active Area

c. Vertical Stripe Pattern

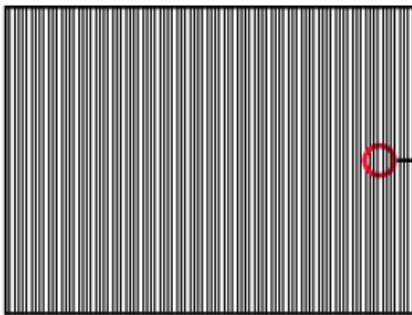

Active Area



Note (4) The power consumption is specified at the pattern with the max. current.

Note (5) VID waveform condition

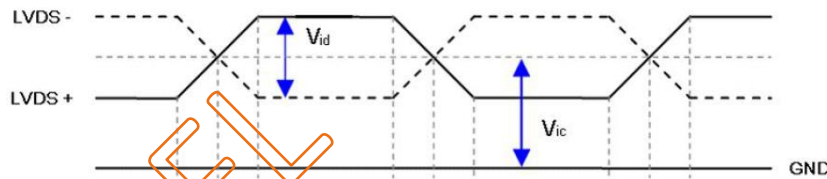

Note (6) Power Dip condition

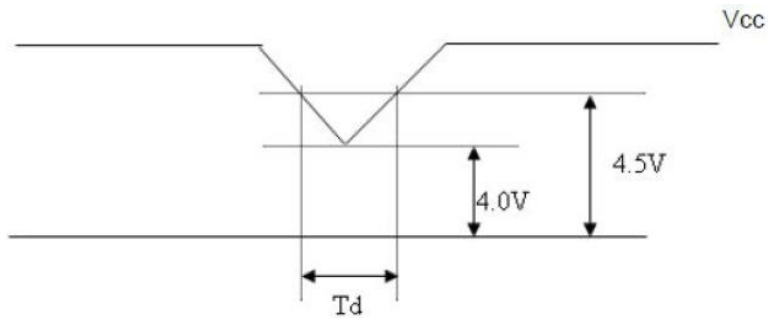

Dip condition:  $4.0 \leq V_{cc} \leq 4.5$ ,  $T_d \leq 20ms$

### 3.2 Backlight Unit

Parameter guideline for LED driving is under stable conditions at 25°C (Room Temperature):

Symbol	Parameter	Min.	Typ.	Max.	Unit	Note	
LED_Vin	Converter Power Supply Voltage	10.8	12.0	13.2	V		
Ii	Converter Power Supply Current	0.6	0.8	1.0	A	@LED_Vi=12V (Duty 100%)	
P <sub>LED</sub>	BLU Power consumption	--	--	10.5	W	@LED_Vi=12V (Duty 100%)	
LED_EN	EN Control Level	Backlight on	2.0	3.3	5.0	V	
		Backlight off	0	0	0.8	V	
LED_PWM	PWM Dimming Control Level	PWM High Level	2.0	3.3	5.0	V	
		PWM Low Level	0	0	0.15	V	
	PWM Dimming Control Duty Ratio	10	--	100	%		
f <sub>PWM</sub>	PWM Dimming Control Frequency	190	200	20K	Hz		
LL	LED life Time (Typical)	50,000	--	--	Hrs	(2)	

Note (1) LED light bar input voltage and current are measured by utilizing a true RMS multimeter as shown below.

Note (2) The lifetime of LED is defined as the time when LED packages continue to operate under the conditions at  $T_a = 25 \pm 2 \text{ }^\circ\text{C}$  and  $I = 70 \text{ mA}$  (per chip) until the brightness becomes  $\cong 50\%$  of its original value.

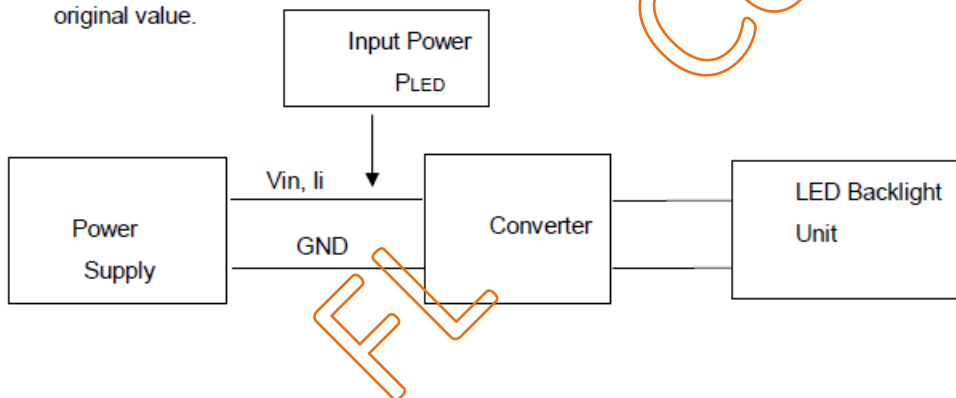



## 4. SIGNAL CHARACTERISTICS

### 4.1 Interface Timing

#### 4.1.1 Timing Characteristics:

Signal	Item	Symbol	Min.	Typ.	Max.	Unit	Note
LVDS Clock	Frequency	Fc	63	76	96	MHZ	
	Period	Tc	--	13.15	--	ns	
	Input cycle to cycle jitter	Trcl	-0.02*Tc	--	0.02*Tc	ns	(3)
	Input Clock to data skew	TLVCCS	-0.02*Tc	--	0.02*Tc	ps	(4)
	Spread spectrum modulation range	F <sub>clk<sub>in</sub>_mod</sub>	Fc*98%	--	Fc*1.02	MHZ	(5)
	Spread spectrum modulation frequency	F <sub>SSM</sub>	--	--	200	KHz	
Vertical Display Term	Frame Rate	Fr	50	60	76	Hz	Tv=Tvd+Tvb
	Total	Tv	800	806	815	Th	--
	Display	Tvd	768	768	768	Th	--
	Blank	Tvb	32	38	47	Th	--
Horizontal Display Term	Total	Th	1500	1560	1570	Tc	Th=Thd+Thb
	Display	Thd	1366	1366	1366	Tc	--
	Blank	Thb	134	194	204	Tc	--

Note (1) Because this module is operated by DE only mode. Hsync and Vsync input signals are ignored.

Note (2) The Tv must be integer, otherwise, this module would operate abnormally.

#### INPUT SIGNAL TIMING DIAGRAM

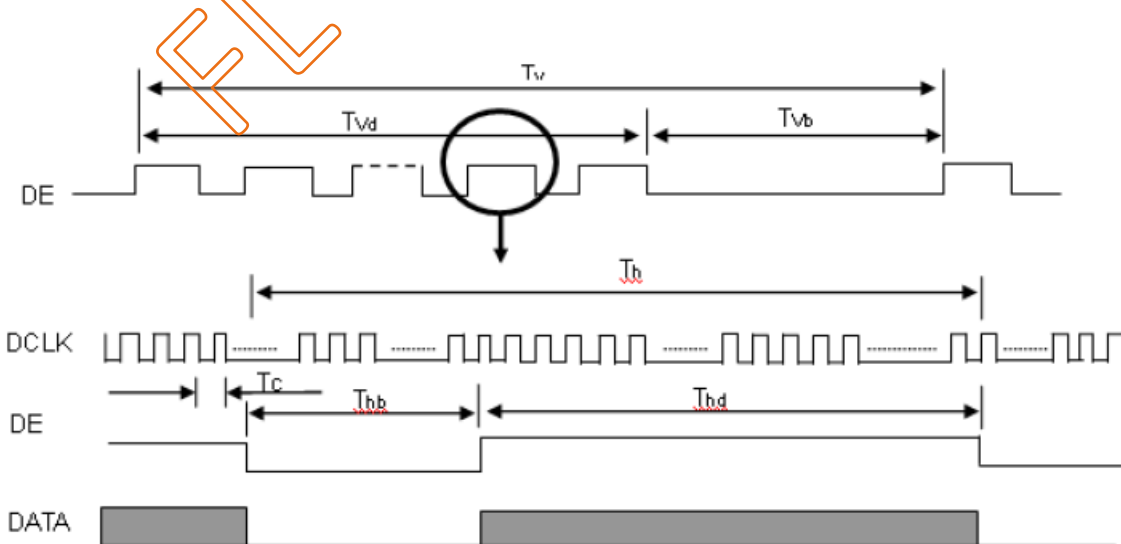

Note (3) The input clock cycle-to-cycle jitter is defined as below figures.  $Trcl = |T1 - T|$

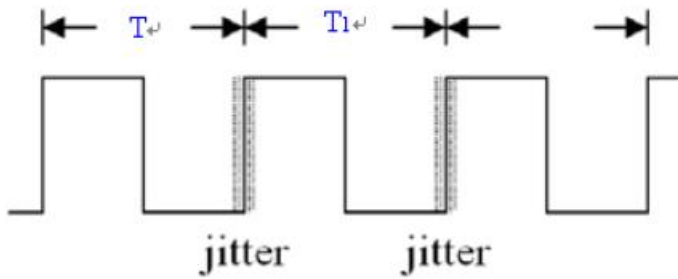

Note (4) Input Clock to data skew is defined as below figures.

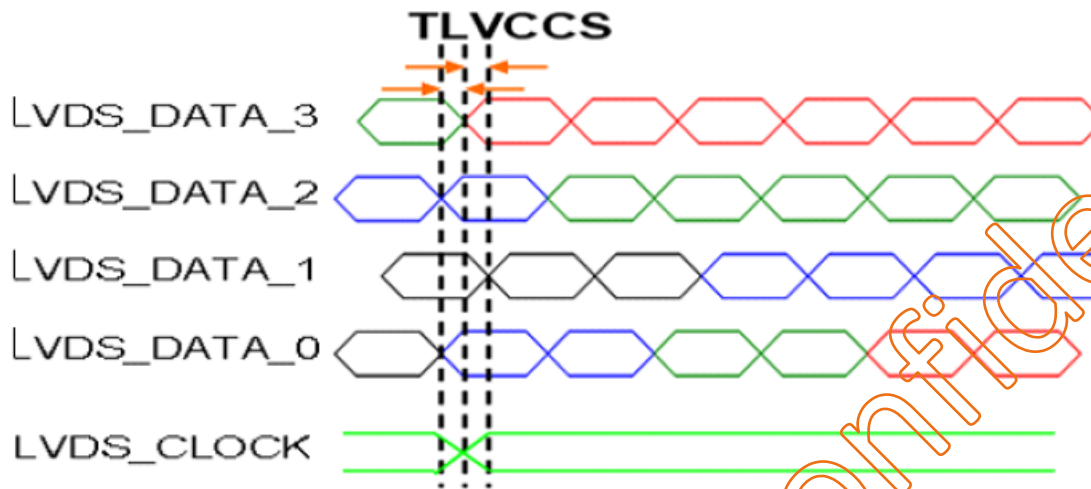

Note (5) The SSCG (Spread spectrum clock generator) is defined as below figures.

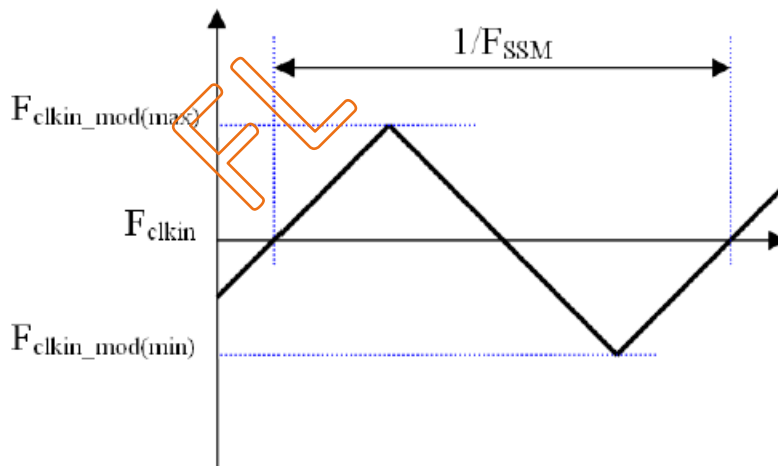

#### 4.1.2 Power ON/OFF Sequence

To prevent a latch-up or DC operation of LCD assembly, the power on/off sequence should be as the diagram below.

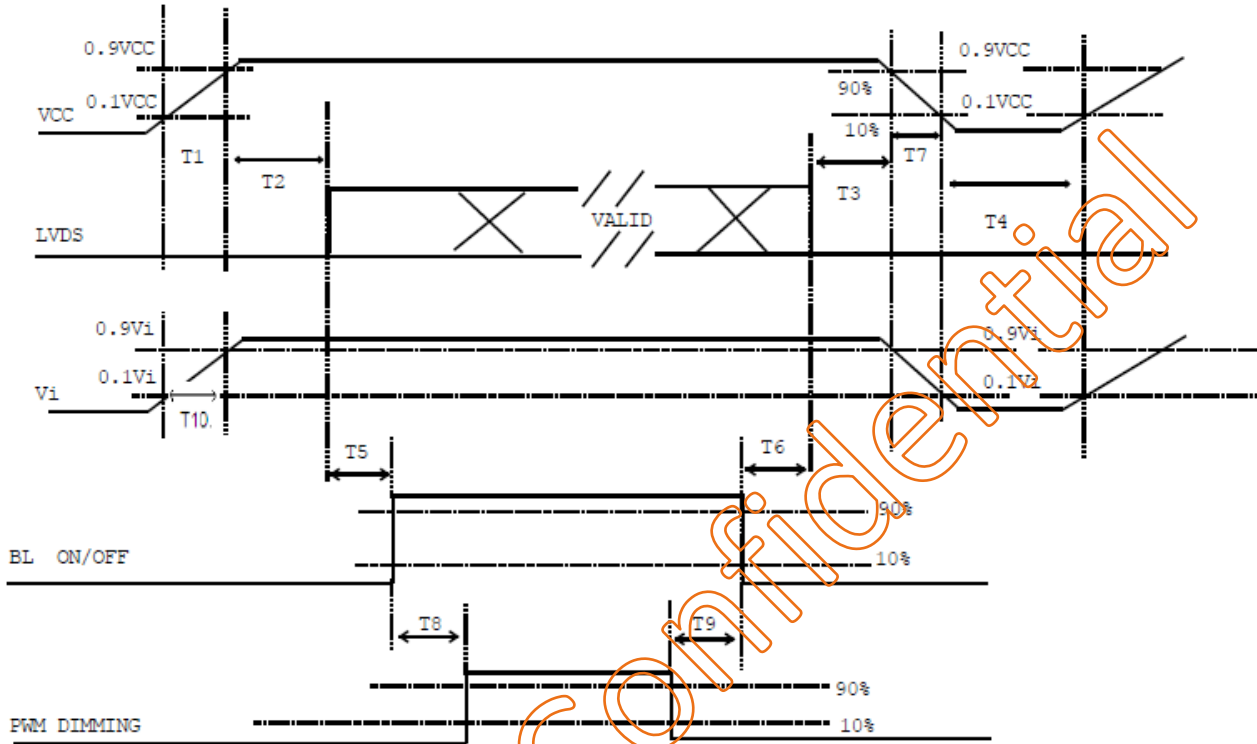

Note (1) Please avoid floating state of interface signal at invalid period.

Note (2) When the interface signal is invalid, be sure to pull down the power supply of LCD VCC to 0V.

Note (3) The Backlight converter power must be turned on after the power supply for the logic and the interface signal is valid. The Backlight converter power must be turned off before the power supply for the logic and the interface signal is invalid.

Parameter	Value			Units
	Min	Typ	Max	
T1	0.5	-	10	ms
T2	0	-	50	ms
T3	0	-	50	ms
T4	500	-	-	ms
T5	200	-	-	ms
T6	20	-	-	ms
T7	5	-	300	ms
T8	10	-	-	ms
T9	10	-	-	ms
T10	20	--	--	ms

## 4.2 Pixel Format Image

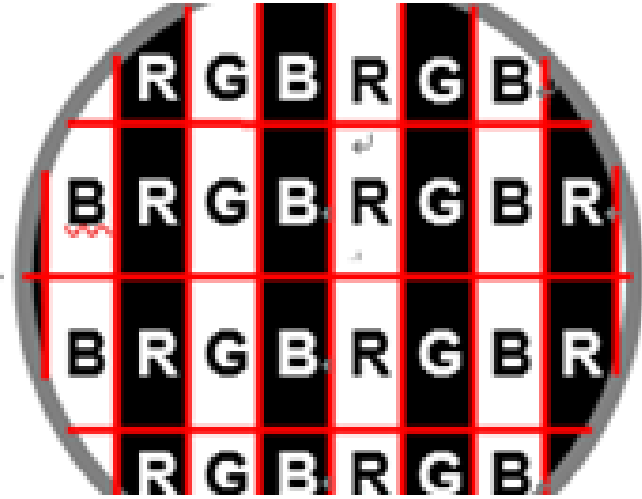

Confidential



## 5. INTERFACE PIN DESCRIPTION

### 5.1 LCM Connector PIN Assignment

	Symbol	Description	Note
1	NC	No Connection	-
2	NC	No Connection	-
3	NC	No Connection	-
4	GND	Ground	-
5	RX0-	Negative LVDS differential data input Channel0	-
6	RX0+	Positive LVDS differential data input Channel0	-
7	GND	Ground	-
8	RX1-	Negative LVDS differential data input Channel 1	-
9	RX1+	Positive LVDS differential data input Channel 1	-
10	GND	Ground	-
11	RX2-	Negative LVDS differential data input Channel 2	-
12	RX2+	Positive LVDS differential data input Channel 2	-
13	GND	Ground	-
14	RXCLK-	Negative LVDS differential clock input	-
15	RXCLK+	Positive LVDS differential clock input	-
16	GND	Ground	-
17	RX3-	Negative LVDS differential data input Channel 3	-
18	RX3+	Positive LVDS differential data input Channel 3	-
19	GND	Ground	-
20	NC	No Connection	-
21	NC	No Connection	-
22	NC	No Connection	-
23	GND	Ground	-
24	GND	Ground	-
25	GND	Ground	-
26	Vcc	+5V power supply	-
27	Vcc	+5V power supply	-
28	Vcc	+5V power supply	-
29	Vcc	+5V power supply	-
30	Vcc	+5V power supply	-

Note (1) Connector Part no.: MSCK2407P30.D(STM)

Note (2) The first pixel is odd.

Note (3) Input signal of even and odd clock should be the same timing.

## 5.2 Backlight and LED Driver Connector PIN Assignment

Pin No	Symbol	Description	Remark
1	Vi	Converter input voltage	12V
2	V <sub>GND</sub>	Converter ground	Ground
3	EN	Enable pin	3.3V
4	ADJ	Backlight Adjust	PWM Dimming (Hi: 3.3V <sub>DC</sub> , Lo: 0V <sub>DC</sub> )
5	NC	Not Connect	

Note (1) Connector Part No.: CI4205M2HRP-NH, CVILUX

Confidential



## 6. BLOCK DIAGRAM

The following diagram shows the functional block of the TFT module:

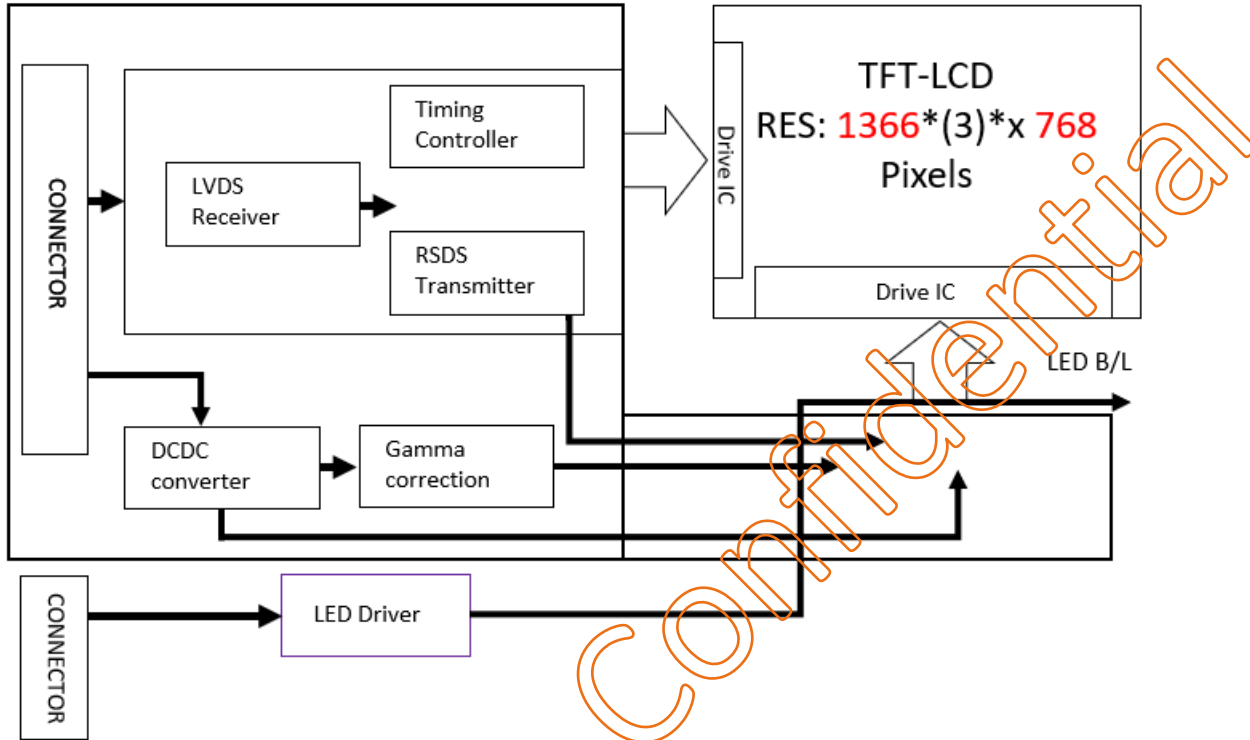

## 7. OPTICAL CHARACTERISTIC

The optical characteristics are measured under stable conditions at room temperature.

Item		Symbol	Condition	Min.	Typ.	Max.	Unit	Note	
Contrast Ratio		CR	$\theta_x=0^\circ, \theta_y=0^\circ$ Viewing angle at normal direction	400	600	-	-	(2)(5)	
Response Time		$T_R$		-	3	8	ms	(3)	
		$T_F$		-	8	13	ms		
Center Luminance of White		LC		400	500	-	cd/m <sup>2</sup>	(4)(5)	
White Variation		$\delta W$		70	--	--	%	(5)(6)	
Chromaticity	Red	$R_x$		$\theta_x=0^\circ, \theta_y=0^\circ$ Viewing angle at normal direction	Typ.	Typ.	+0.045	-	(1)
		$R_y$	0.627						
	Green	$G_x$	0.339						
		$G_y$	0.328						
	Blue	$B_x$	0.160						
		$B_y$	0.063						
	White	$W_x$	0.313						
		$W_y$	0.329						
Viewing Angle	Horizontal	$\theta_{x+}$	70	80	-	Deg.	(1)(5)		
		$\theta_{x-}$	70	80	-				
	Vertical	$\theta_{y+}$	65	75	-				
		$\theta_{y-}$	65	75	-				

The following optical specifications shall be measured in a darkroom or equivalent state (ambient luminance <2 lux, and at room temperature).

The ambient temperature is  $25^\circ\text{C} \pm 2^\circ\text{C}$  and ambient humidity is  $50 \pm 10\% \text{RH}$ .

### Note 1: Definition of Viewing Angle

Viewing angle is the angle at which the contrast ratio is greater than 10. The viewing angles are determined for the horizontal or the vertical clock direction with respect to the optical axis which is normal to the LCD surface

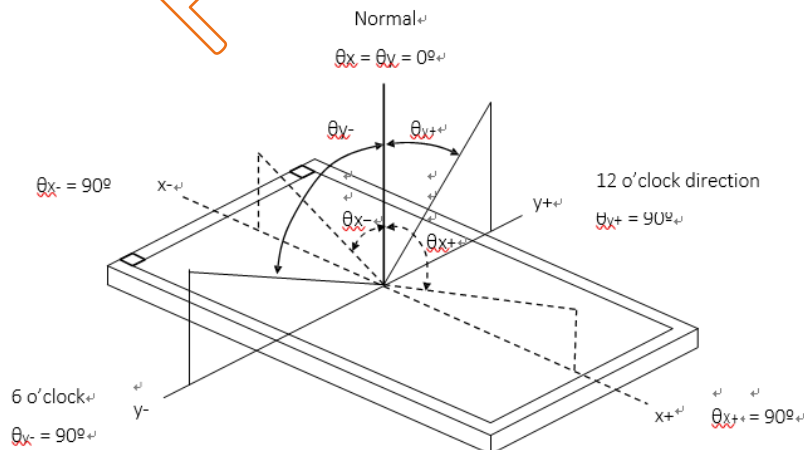



Note 2: Definition of Contrast Ratio (CR)

Measure the viewing angle of  $\Theta = 0$  and at the center of the LCD surface. Luminance with all pixels in white state divide by Luminance with all pixels in Black state

Note 3 Definition of Response Time:

The response time is set initially by defining the “Rising Time ( $T_R$ )” and the “Falling Time ( $T_F$ )” respectively. Please refer the figure to the followings:

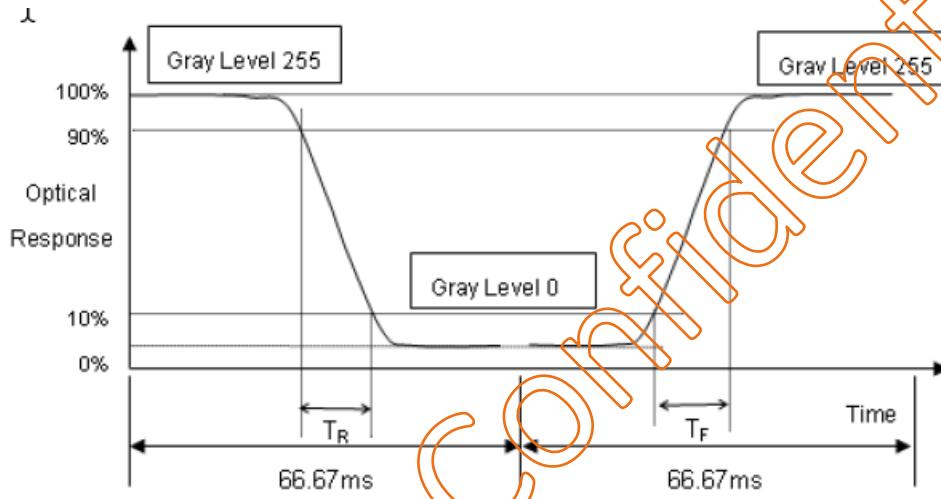

Note 4: Definition of Brightness (Lc)

Measure the center area of the panel and the viewing angle of the  $\theta_x = \theta_y = 0^\circ$

Note 5: The method of optical measurement:

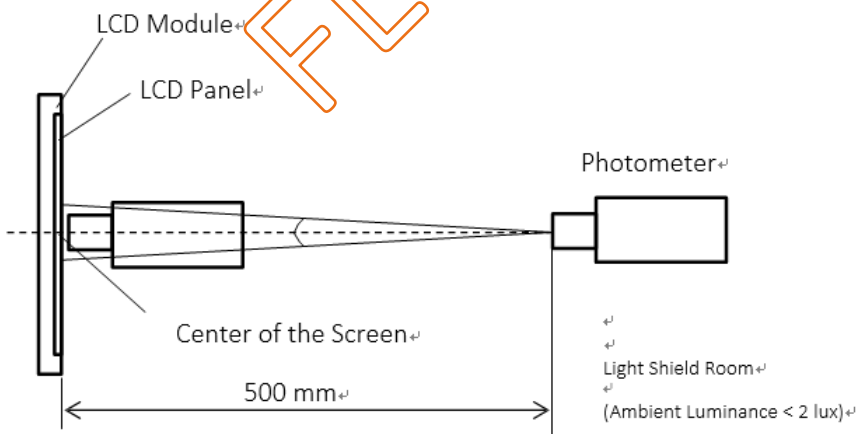

Note 6: Definition of White Variation ( $\delta W$ ):

Measure the luminance of gray level 255 at 5 points

$$\delta W = \text{Maximum [L (1), L (2), L (3), L (4) \sim L (9)]} / \text{Minimum [L (1), L (2), L (3), L (4) \sim L (9)]}$$

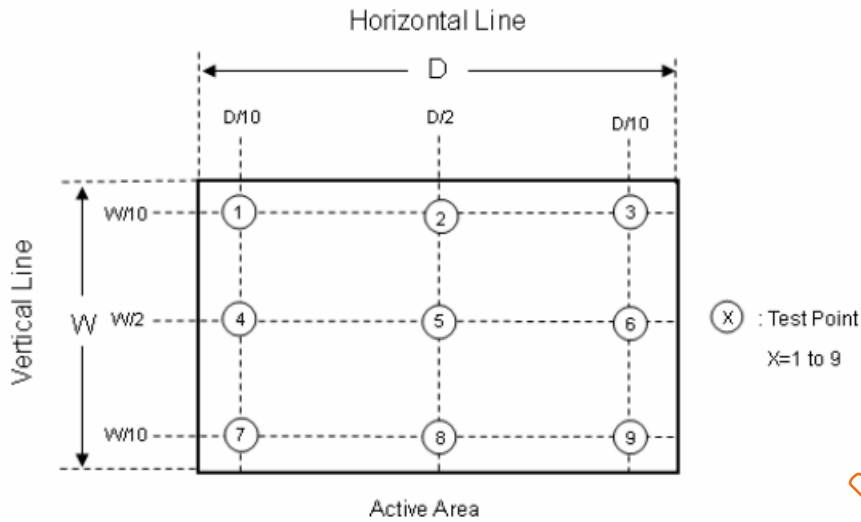

Confidential



## B. Touch Screen specification

### 1. Environmental Specification

Specification	Value	Remarks
Operating Temperature	-20°C ~ 70°C	
Storage Temperature	-40°C ~ 80°C	
Operating Humidity	20% ~ 90%RH	
Storage Humidity	10% ~ 90%RH	

### 2. Mechanical Specification

Specification	Value
Operating Life (Finger input)	10 <sup>7</sup> times
Light Transmittance	>85% Min. (JIS K-7105) with glass
Surface hardness	6H
FPC Peeling Force	5N Max

### 3. USB Type Controller

Parameters	Features
Circuit Board Dimension	Refer to drawings
Channels of Panel	Based on Sensor Design
Input Voltage	5V for USB
Linearity(Note 1)	Single Line drawing accuracy : Up to 1pt +/- 1mm offset /10mm
	Single Touch (point) accuracy : Up to 1pt +/- 1mm
Interface	USB: 2.0(Below) Full Speed
Resolution	4096×4096 resolution
Power consumption(mA)	Active Mode: <70mA
	Idle Mode : <55mA
	Sleep Mode :< 15mA
	(Operation Mode :Active Mode only)
Report rate(points/sec) Note(2)	> 100 Hz
Response time	Average < 25 ms

Note (1): Depending by Sensor design and other parameters, Refer to Windows 8 Logo regulation if need to follow min spec

Note (2): Report rate will vary by channel number, cover thickness, number of fingers and other parameters

## C. DIMENSION AND DRAWING

Front VIEW

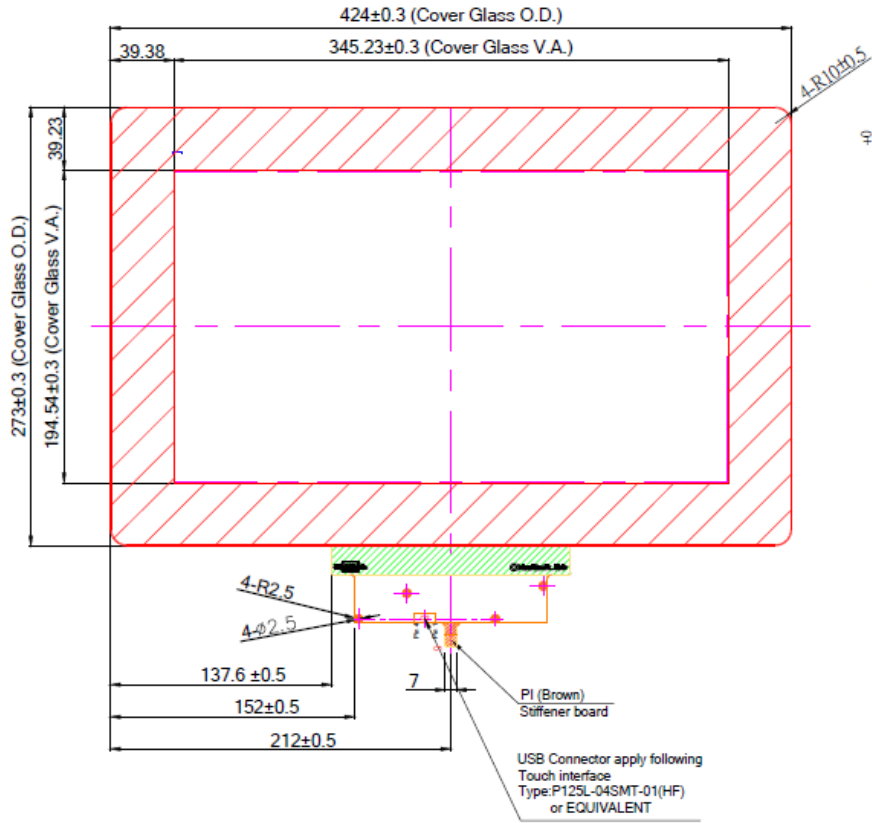

Back VIEW

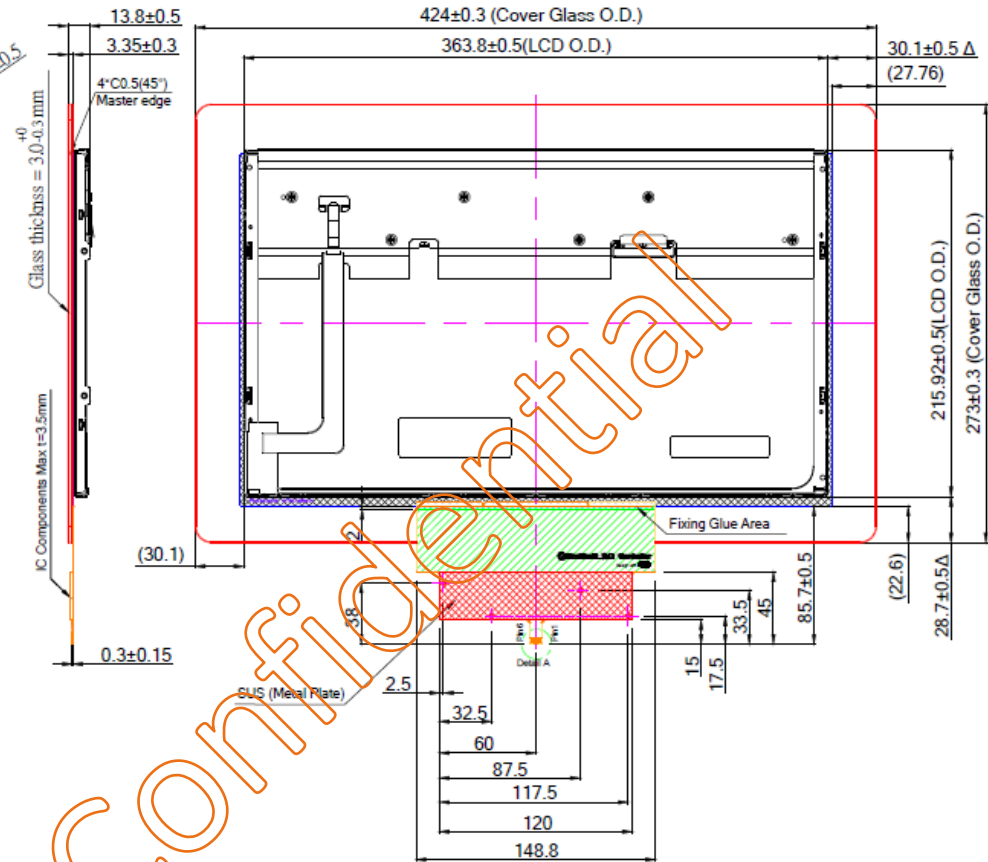

**Note:**

1. Tolerance: ±0.5mm
2. Touch finger input or special conductive pen
3. Touch Surface Hardness: 6H (Semi Tempered Glass)
4. Touch Transmittance: >85% (JIS-K7105)
5. Touch Surface Treatment: None
6. If customer put a front cover all around need use at least 2mm thick gasket between touch and metal frame
7. USB max ripple acceptable is 50mV, in other case touch will not work correctly
8. Referring to the integration guide to avoid any integration noise issue
9. LCD model : FLC-156ITL2000SA1
10. Touch model : RTPC156W-H30BP1-U

C2:Pin Define for USB 4 pin		C1:USB Interface	
Pin 01	GND	Pin 01	GND
Pin 02	D-	Pin 02	D-
Pin 03	D+	Pin 03	D+
Pin 04	VDD	Pin 04	VDD
		Pin 05	NC
		Pin 06	RST

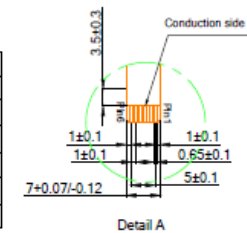

Customer Approval		Part Number		FLD-156ITL20PUSA2	
Date	Rel. Date	Person	Description		
Company					
Name					
Signature	Date	Design By	Date	Check By	Approved By
	First Drawing 20170821	Kevin			

1. eDP Converter Board  
P/N : TFC\_UP2EDP

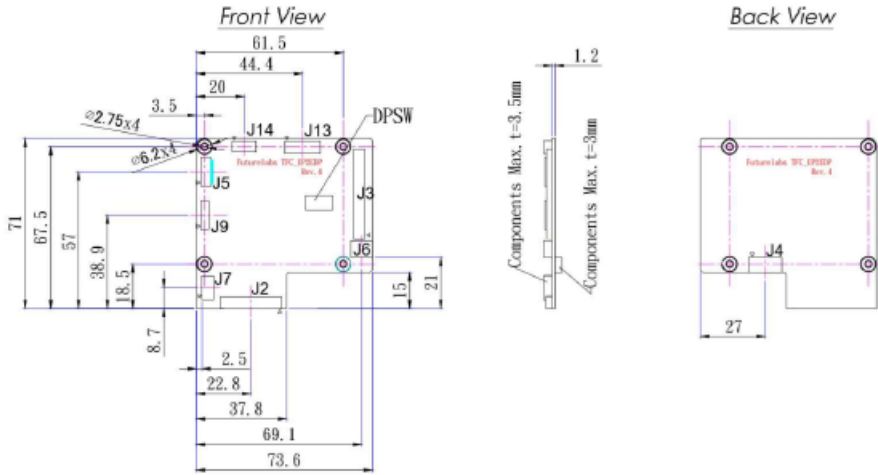

2. eDP to eDP Cable  
P/N : CBL-41-03-100-A



3. LVDS Cable  
P/N : CB-EDP2G156BGE

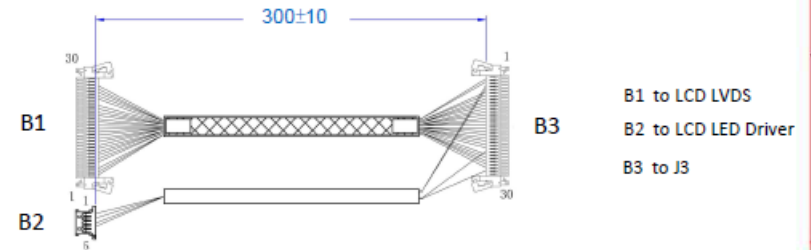

4. Internal USB Cable  
P/N : CB\_UP2USB8

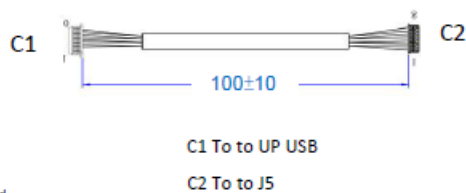

DPSW selection for 15.6"W



Connector table of eDP Converter Board

Connector Number	Function	Cable
J2	No use	No use
J3	LVDS from 10.1"W up to 21.5"W	CB-EDP2G156BGE
J5	8 pin UB to 10 Pin USB UP	CB_UP2USB8
J6	No use	No use
J7 & J14	USB interface for Touch 10.4 up to 21.5"W	CB-EDPB2USB4-200
J9	eDP to UP Board eDP-DSI	CBL-41-03-100-A
J13	Power Input for LCD backlight from 10.4"W up to 21.5"W	CB-EDP2DCJACK

5. Touch USB Cable 4 to 4 pin  
P/N : CB-EDPB2USB4-200

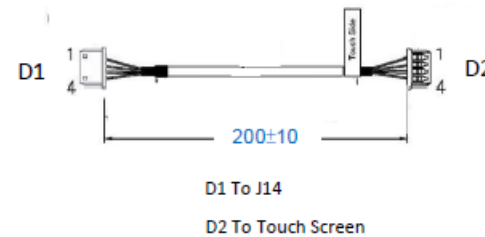

6. External Backlight power  
P/N : CB-EDP2DCJACK

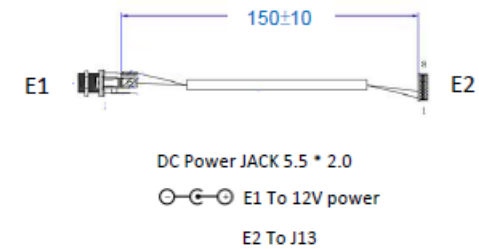

Customer Approval		Part Number		KIT-156ITL20PUSA2B	
Date	Person	Part Name	Person	Date	Description
Company Name					
Signature	Date	Design By	Date	Check By	Date
	Part Control				Approved By

## D. PRECAUTION AND PRODUCT HANDLING

- Do not apply the external force such as bending or twisting to the module during assembly.
- Do not insert and plug out the input connector while the LCD panel is operating.
- Do not take apart the panel or frame from module assembly or insert anything into the backlight unit.
- Do not keep the same pattern in a long period of time, it may cause image sticking on LCD panel. Can use shuffle content periodically if fixed pattern is displayed on the screen.
- Do not touch the display area with bare hands, this will stain the display area.
- Pay attention to handle lead wire of backlight, that is not tugged in connect with LED driver.
- Do not change variable resistance settings in LCD panel, it may cause not satisfy of LCD characteristics specification.
- To avoid the static electricity to damage the CMOS LSI, the operator should be grounded when in contact with the LCD panel, and also to all electrical equipment.
- Need to follow the correct power frequency when LCD panel is connecting and operating, this can avoid damage to CMOS LSI during latch-up.
- Need to store the LCD panel indoor without the exposure of sunlight where the temperature is  $25^{\circ}\text{C} \pm 5^{\circ}\text{C}$  and the humidity is below 60% RH.



**Distributed by:**



## The Netherlands



Elektrostraat 17  
NL-7483 PG Haaksbergen

T: +31 (0)53 573 33 33  
F: +31 (0)53 573 33 30  
E: [nl@texim-europe.com](mailto:nl@texim-europe.com)

## Belgium



Zuiderlaan 14 bus 10  
B-1731 Zellik

T: +32 (0)2 462 01 00  
F: +32 (0)2 462 01 25  
E: [belgium@texim-europe.com](mailto:belgium@texim-europe.com)

## UK & Ireland



St. Mary's House, Church Lane  
Carlton Le Moorland  
Lincoln LN5 9HS

T: +44 (0)1522 789 555  
F: +44 (0)845 299 22 26  
E: [uk@texim-europe.com](mailto:uk@texim-europe.com)

## Germany North



Bahnhofstrasse 92  
D-25451 Quickborn

T: +49 (0)4106 627 07-0  
F: +49 (0)4106 627 07-20  
E: [germany@texim-europe.com](mailto:germany@texim-europe.com)

## Germany South



Martin-Kollar-Strasse 9  
D-81829 München

T: +49 (0)89 436 086-0  
F: +49 (0)89 436 086-19  
E: [germany@texim-europe.com](mailto:germany@texim-europe.com)

## Austria



Warwitzstrasse 9  
A-5020 Salzburg

T: +43 (0)662 216 026  
F: +43 (0)662 216 026-66  
E: [austria@texim-europe.com](mailto:austria@texim-europe.com)

## Nordic region



Sdr. Jagtvej 12  
DK-2970 Hørsholm

T: +45 88 20 26 30  
F: +45 88 20 26 39  
E: [nordic@texim-europe.com](mailto:nordic@texim-europe.com)

## Italy



Via Matteotti 43  
IT-20864 Agrate Brianza (MB)

T: +39 (0)395 967 226  
F: +39 (0)395 967 226  
E: [italy@texim-europe.com](mailto:italy@texim-europe.com)

## General information



[info@texim-europe.com](mailto:info@texim-europe.com)  
[www.texim-europe.com](http://www.texim-europe.com)