

1 INTRODUCTION

The GNS1201 module utilizes the new generation MediaTek MT3339 GPS chip. The navigation performance and accuracy is further improved by using correction data from SBAS (WAAS, EGNOS, GAGAN, MSAS), QZSS or connectivity to DGPS (RTCM format).

First Fixes after just a few seconds are achieved with the help of A-GPS using EPO™ (Extended Prediction Orbit) and the EASY™ "self generated orbit prediction" algorithm. EASY™ (Embedded Assist System) does not require any resources or assist data from the host.

The excellent low power design makes it easy to implement this module in power sensitive, battery supplied applications. The new AlwaysLocate™ power management feature will improve this behaviour additionally. It adaptively adjusts power consumption depending on the environment and motion conditions, in order to achieve a balance between fix rate, power consumption and position accuracy.

Very low power requirements (typ 66mW@ 3.3V) and internal voltage regulator makes it easy to run the module with various power supplies and allows direct connection to LiIon batteries.

GNS1201 offers the industry's highest level of navigation sensitivity up to -165dBm. It has superior dynamic performance at high velocity and provides effective protection against interference signals using MTAIC™ (Multi-tone active interference canceller). Up to 12 independent channel interference continuous wave jammers <-80dBm can be eliminated or reduced.

The embedded logger function LOCUS with a 16-hrs on chip memory makes this GPS module a complete track logger for many applications. With AlwaysLocate™ data logging can be achieved up to 32-hrs under standard conditions.

In professional timing applications the outstanding high accuracy PPS (pulse per second) hardware pin is used for synchronization to GPS second. Typical accuracy is 10ns.

.

Features

- 66 acquisition-/ 22 tracking channels
- Ultra high tracking/navigation sensitivity: -165dBm
- Extremely fast TTFF at low signal level
- QZSS, SBAS (WAAS,EGNOS,MSAS,GAGAN) and DGPS(RTCM) correction support
- A-GPS by EPO "Extended Prediction Orbit"[™] enables 7/14days prediction
- 12 Multitone Active Interference Canceller for GPS-in-band jammer rejection
- EASY[™] : Self generated orbit prediction support
- AlwaysLocate[™] : Intelligent Algorithm for power saving
- High accuracy 1PPS output
- NMEA-0183 or binary protocol
- High update rate (up to 10/s)
- Embedded logger function with 16hrs internal memory
- GPS current consumption (@3.3V):
 - Acquisition: 25mA Typical
 - Tracking: 20mA Typical
- Low backup current consumption 7uA, typical
- internal power management saves extra LDO
- SMD type with stamp holes
- Small form factor: 11.5x13x2.1 mm
- CE, FCC and RohS certified

Applications

- Navigation
 - In-vehicle Navigation equipment
 - Dynamic Navigation
 - Netbooks, tablet PCs and mobile phones
- Timing
 - Precision timing via GPS
- Location based applications
 - GPS Logger
 - GPS Tracker
 - Security devices
 - Camera equipment

2 INDEX

1 INTRODUCTION -----	1
2 INDEX -----	3
3 FUNCTIONAL DESCRIPTION -----	4
3.1 Block diagram -----	4
3.2 System description -----	4
3.3 Power management features -----	5
3.4 Logger function -----	6
3.5 Active interference cancellation -----	7
3.6 AGPS with EPO data -----	7
3.7 EASY™ self generated prediction data feature -----	8
3.8 Pulse Per Second (PPS) -----	8
3.9 SBAS (Satellite Based Augmentation) support -----	9
3.10 DGPS (Differential GPS) support -----	9
3.11 Single sentence output -----	9
3.12 Last position retention -----	9
3.13 Geofencing function -----	9
3.14 Distance calculation feature -----	10
3.15 Magnetic variation feature -----	10
3.16 High altitude unlimiter -----	10
3.17 GPS almanac and ephemeris data -----	10
3.18 Real time clock (RTC) -----	10
3.19 UART interface -----	10
3.20 Module default settings -----	10
4 TYPICAL APPLICATION BLOCK DIAGRAM -----	11
4.1 Typical System overview -----	11
5 GPS characteristics -----	12
5.1 GPS characteristics -----	12
6 DESIGN GUIDELINES -----	13
6.1 General -----	13
6.2 GPS antenna -----	13
7 ELECTRICAL SPECIFICATION -----	14
7.1 Absolute Maximum Ratings -----	14
7.2 Recommended Operating Conditions -----	14
7.3 GPS input characteristics -----	14
8 DEVICE PINOUT DIAGRAM -----	15
9 NMEA DATA interface -----	17
9.1 NMEA output sentences for GPS -----	17
9.2 NMEA command interface -----	18
10 PHYSICAL DIMENSIONS -----	19
11 RECOMMENDED PAD LAYOUT -----	20
12 MATERIAL INFORMATION -----	21
13 RECOMMENDED SOLDERING REFLOW PROFILE -----	21
14 TRAY PACKAGE INFORMATION -----	22
15 ORDERING INFORMATION -----	22
16 FCC AND CE COMPLIANCE -----	22
17 ENVIRONMENTAL INFORMATION -----	23
18 MOISTURE SENSITIVITY -----	23
19 DOCUMENT REVISION HISTORY -----	23
20 RELATED DOCUMENTS -----	23

3 FUNCTIONAL DESCRIPTION

3.1 Block diagram

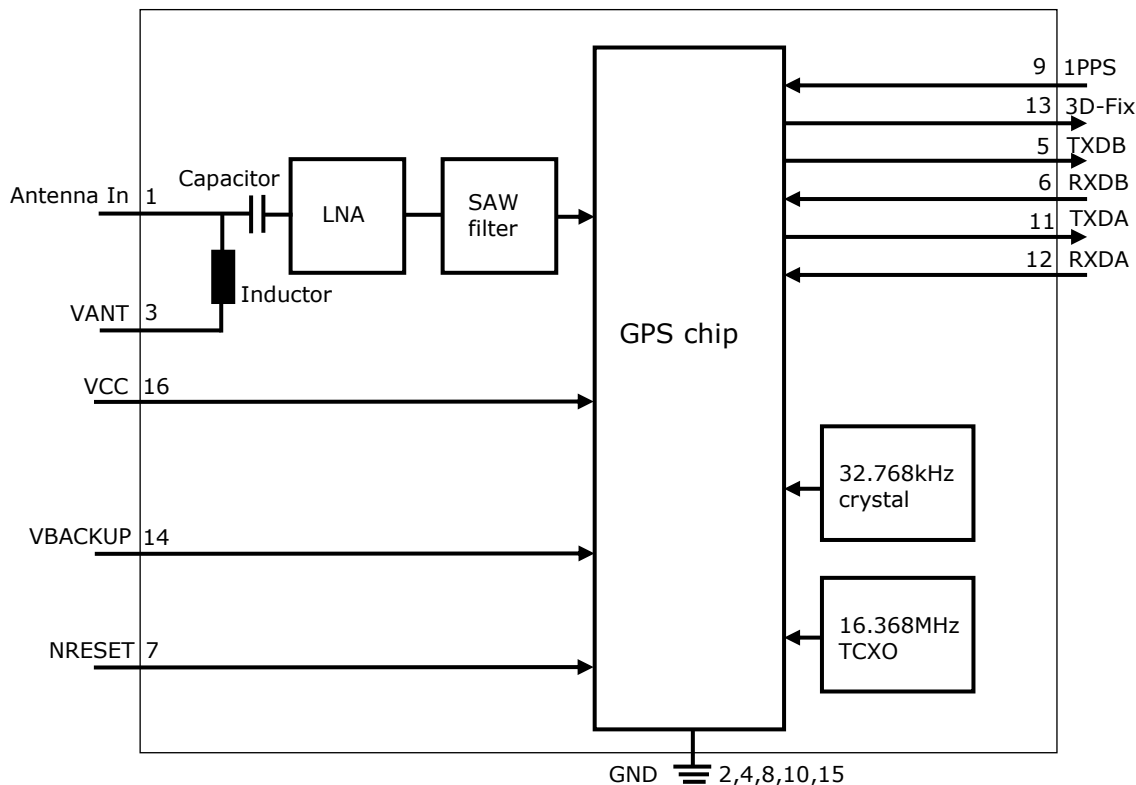

3.2 System description

The GNS1201 core is a high performance, low power GPS receiver that includes an integrated RF frontend. The integrated LNA reaches a noise figure of just 0.7dB thus providing superior performance with direct connection of a passive GPS antenna.

GNS1201 is a complete GPS engine, including.

- Full GPS processing without any host processing requirements
- Standard NMEA message output
- A powerful command and control interface
- All clock sources integrated on module
- RF frontend for direct connection of passive or active antennas
- Rich additional features like complete logger, geofencing, single sentence output, last position retention, high altitude unlimiter and magnetic variation
- Interfaces for DGPS, PPS, FixStatusIndicator

3.3 Power management features

Power management schemes implemented for any GPS system requires an optimally tuned performance for both accuracy of the position fixes and the average power consumed for best user experience. GNS1201 architecture achieves both these aspects by providing flexibility and design choices for the system integration based on wide range of use cases and by leveraging on the proven silicon methodologies. Also GNS1201 provides position, velocity and time measurements without any host loading. This, coupled with the optional built-in power management options, reduces the overall system power budget.

Power management features:

- In **Standby mode** RF frontend and internal MPU are switched to deep sleep state. Power consumption is reduced to 1.32 mW (400µA). This state can be entered by sending the NMEA command: \$PMTK161,0*28<CR><LF>. Leaving standby mode and resuming to normal operation will be managed by sending any byte to the module.

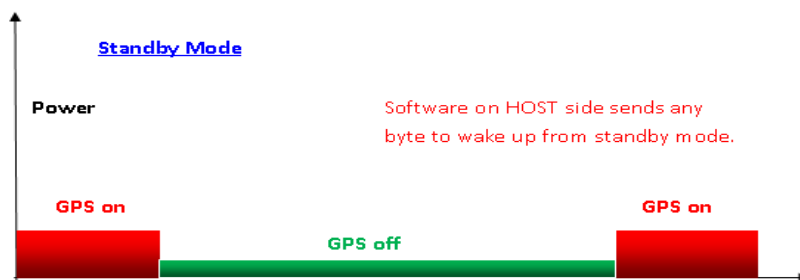

- Backup mode** can be entered by sending NMEA command: \$PMTK225,4*2F<CR><LF>. The GPS core will shut down autonomously to backup state, Vcc supply can now be switched off by an external power supply switch.
- Periodic mode** describes a power mode, which will autonomously power on/off the module in programmable time slots with reduced fix rate. Periodic mode is useful during stationary operation or if position fixes are just needed from time to time. Since power consumption in **GPS off** times is nearly zero, the power consumption in periodic mode can be estimated by $P_{\text{tracking}} * (t_{\text{on}} / (t_{\text{on}} + t_{\text{off}}))$. Periodic mode is controlled with NMEA command \$PTMK225. See document *NMEAcommandInterface manual* for programming details.

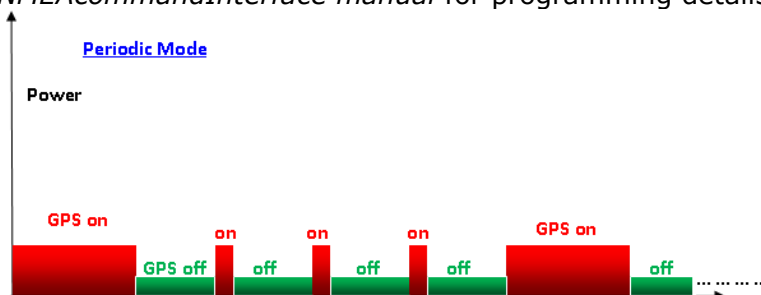

- **AlwaysLocate™** feature provides an optimized overall GPS system power consumption in tracking mode under open sky conditions. Always Locate is an intelligent control of periodic mode. Depending on the environment and motion conditions, GNS1201 can adjust the on/off time to achieve balance of positioning accuracy and power consumption. The best power saving will be made under good reception in stationary mode. Critical reception conditions and dynamic movements will need full activity of the GPS engine which causes nominal power requirements.

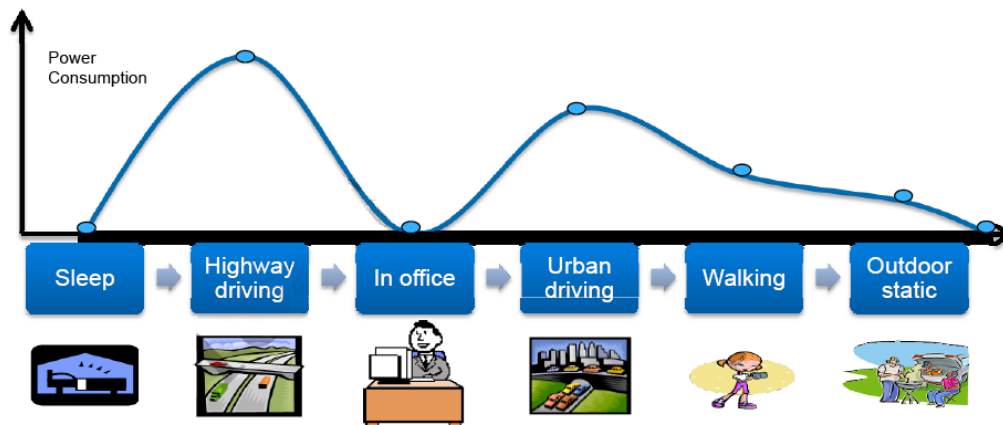

3.4 Logger function

GNS1201 provides an autonomous logger function that automatically stores position information in an internal 128kB flash memory. A complete tracking unit can be realized without any external CPU or memory. With AlwaysLocate™ data logging can be achieved up to 32-hrs under standard conditions.

The parameters for logging are programmable via the NMEA command interface. The following parameters can be set to optimize content and logging time:

- logger rate

The commands for logger include:

- start logging
- stop logging
- erase memory
- readout memory

please refer to the *NMEACommandInterface* manual for details.

Internal Logger Function					
Logger data rate	1/15		1	1/s	
Logger data memory		128		kBytes	Flash memory
Logger trigger		Programmable			Logger can be triggered on various events

3.5 Active interference cancellation

Because different wireless technologies like Wi-Fi, GSM/GPRS, 3G/4G, Bluetooth are integrated into portable systems, the harmonic of RF signals may influence the GPS reception.

The multi-tone active interference canceller can reject external RF interference which come from other active components on the main board, thus improving the performance of GPS reception. GNS1201 can cancel up to 12 independent continuous wave (CW) channels having signal levels of up to -80dBm. The functionality is enabled by default and increases power consumption by about 1mA.

3.6 AGPS with EPO data

AGPS (assisted GPS) allows to shorten TTFF (TimeToFirstFix) by injecting ephemeris data from an external source into the module's memory. With the help of these data, the module does not need to acquire satellite positions by receiving the data from the satellites.

Depending on time and position information that is still available in the module memory, the TTFF can be reduced to just a few seconds.

The GNS AGPS service is based on a short term predicted data service. The predicted data will be fully processed by the GPS engine, the host must load the data from the web and transfer them over the UART to the module:

1. check GNS1201 module EPO data for validity by comparing the time. (time parameters for existing 1201 data can be retrieved through a NMEA command)
2. connect to web server through network connection (GPRS, WLAN, LAN,..)
3. Download file. There are just two files, covering all GPS satellites. The first file (MTK7d.EPO) is for 7 days (53kB), the other is 106Kbytes for 14 days (MTK14d.EPO)
4. "parse" file, using software example. This is quite easy, there must be added some header bytes and a checksum and a control counter. GNS offers software support on this.
5. download to 1201 module. please refer to the *NMEACommandInterface manual* for details

If the host has low memory available, there's no need to save the whole file. The steps 3..5 can be done frame by frame needing less than 2kBytes of buffer memory.

Code samples and support for several platforms are available from GNS (in preparation)

Thanks to the predicted system, download data stay valid for up to 14 days. Therefore, users can initiate the download everytime and benefit from using (W)LAN instead of using expensive GSM. File size will be ~50kBytes for a one week prediction data set.

AGPS characteristics					
System					6hrs predicted data
File size for data download		53		kB	1 week prediction data
Maximum prediction time		14		days	
TTFF		1		sec	Time and last position available
TTFF		15		sec	Last position available

3.7 EASY™ self generated prediction data feature

GNS1201 includes an internal prediction system, that allows to sample satellite orbit data during operation and use that data to speed up TTFF on later starts. The prediction time frame is up to three days forward.

Although this prediction feature does not provide the very short TTFF that is achieved using AGPS, it can help to find a fix solution faster and in weak signal condition scenario. Prediction data will be kept in memory as long as VBACKUP is present. This option is activated by default.

Note: The EASY functionality is only supported, if "VBACKUP" pin is connected and the NMEA update rate is 1Hz.

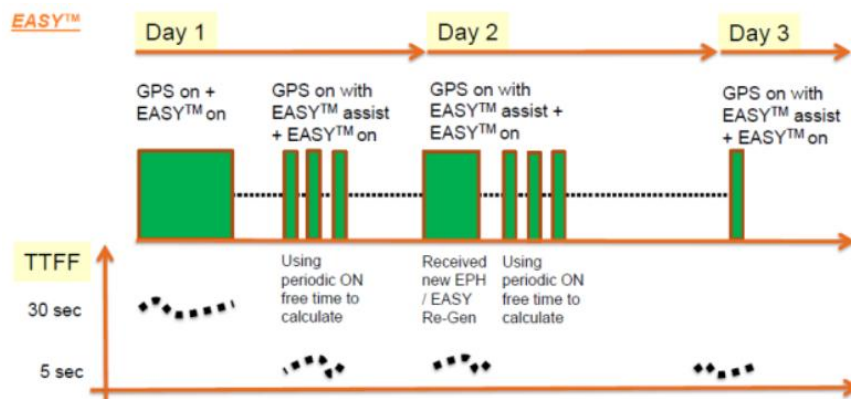

3.8 Pulse Per Second (PPS)

GNS1201 provides a Pulse Per Second (PPS) hardware output pin for timing purposes. After calculation of a 3D position fix, the PPS signal is accurately aligned to the GPS second boundaries. The pulse generated is approximately 100 milliseconds in duration and the repetition rate is 1 second.

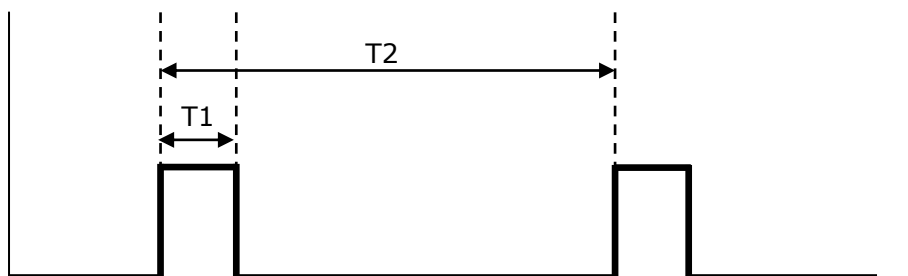

$$T1 = 100\text{ms} \quad T2 = 1\text{sec}$$

GNS1201 module provides an exceptionally low RMS jitter of typical 10 nanoseconds.

PPS characteristics					
1PPS pulse duration	-	100	-	msec	
1PPS time jitter	-	10	tbd	nsec RMS	Pulse rising edge deviation from expected pulse time, measured with full 3D fix
1PPS rise and fall time		5		nsec	10%..90%, load is 10k 5pF

3.9 SBAS (Satellite Based Augmentation) support

GNS1201 supports Satellite Based Augmentation for improvement of the navigation precision. Correction data is sent from geostationary satellites to the GPS receiver. GNS1201 supports European, US, and Asian augmentation systems (EGNOS, WAAS, MSAS) to enable precision improvements in nearly every region of the world.

SBAS is active by default and will automatically track the available SBAS satellites. It can be disabled by NMEA command. See document *NMEACommandInterface manual* for details

Note : in SBAS mode, the maximum fix rate is limited to 5 per second.

3.10 DGPS (Differential GPS) support

GNS1201 accepts DGPS input in RTCM format.

DGPS provides precision position fixes down to centimetres and is used in professional applications like agriculture. The second UART (UART_B) of the module is used to feed the data in. DGPS is deactivated by default. For configuration of the UART port, some NMEA commands must be implemented. See *NMEACommandInterface manual* document for details.

Note : Since SBAS and DGPS both do (different) corrections on the fix position solution, they cannot be used at the same time! SBAS / DGPS usage is programmed through the NMEA Interface.

3.11 Single sentence output

GNS1201 allows to reduce data transfer to host to a minimum. Reduced data transfer can save host processor activity times and thus reduce system power consumption. All relevant information will be provided in a single sentence output. To save further channel load, the sentence can be formatted as binary.

3.12 Last position retention

Depending on the application, it might be useful to retain the last position or to clear the position when having no fix solution. Last position retention can be enabled or disabled. When enabled, the last known position is outputted in the NMEA sentences.

3.13 Geofencing function

GNS1201 has an internal algorithm to determine whether the actual position is within a circular area around a predefined location point. A proprietary sentence indicates the "inside" or "outside" status

3.14 Distance calculation feature

This feature allows to request the real "line of sight" distance in relation to a predefined position. This feature can remove some load from the host processor.

3.15 Magnetic variation feature

As the magnetic variation feature is enabled, data output provides informations about the degree of magnetic variation and the measured magnetic heading.

3.16 High altitude unlimiter

Activating this feature, the GPS module is prepared to work beyond 18000 meter up to 45000 meter.

3.17 GPS almanac and ephemeris data

For quick re-acquisition of the GPS after off-times, the GPS engine should have access to almanac and ephemeris data. This data is permanently stored inside GNS1201 module, even if all power supplies have been removed. When the GPS is powered-up again, the data will be used to allow a quick re-acquisition, as soon as a coarse time information is available. Time will be available immediately, when RTC is kept running.

3.18 Real time clock (RTC)

GNS1201 has a real time clock with 32,768Hz crystal onboard. As long as VBACKUP is connected to a power source, the real time clock and the module memory can be kept alive at very low power consumption of just 7uA. The RTC will track the current time and enable the module to start from sleep states with very fast time to first Fix (TTFF).

3.19 UART interface

GNS1201 core and I/O sections work at 3.3V nominal. Absolute Maximum Ratings should not be exceeded. Should the GNS1201 be interfaced to a host with I/O at higher/lower levels, level shifters should be used. UART baud rate is 9600baud by default. The baud rate can be modified to higher rates by a NMEA software command. See document *NMEACommandInterface manual* for details.

GPS UART Default Settings

Parameter	Value
Baud rate	9600
Data length	8 bits
Stop bit	1
Parity	None

3.20 Module default settings

The 1201 module comes with default settings, which are persistently programmed. Whenever power is removed from the module (both Vcc and VBACKUP), the settings will be reset to the values shown in the following table.

NMEA output sentences	
Setting	Default value
UART setting	9600,8,N,1
Fix frequency (update rate)	1/sec
NMEA sentences	\$GPRMC,\$GPGSA,\$GPGSV,\$GPVTG,\$GPGGA
NMEA rate	Once a second: RMC,GSA,VTG,GGA every 5 sec :GSV
Self survey prediction mode EASY™	enabled
Active interference cancellation MTAIC™	enabled
DGPS option	SBAS enabled
Datum	WGS 84
PPS pulse output length	100ms
Logging parameters	Full&Stop / Content Basic / Interval 15 sec
Single sentence output	Customized firmware needed
Last position retention	Customized firmware needed
Magnetic variation	Customized firmware needed
Geofencing function	Customized firmware needed
Distance calculation	Customized firmware needed
High altitude unlimiter	Customized firmware needed

On request, other options can be selected as preprogrammed (persistent default) options. Please contact the GNS support for your project requirements.
Note : Customized options are solely available for fixed order lots.

4 TYPICAL APPLICATION BLOCK DIAGRAM

4.1 Typical System overview

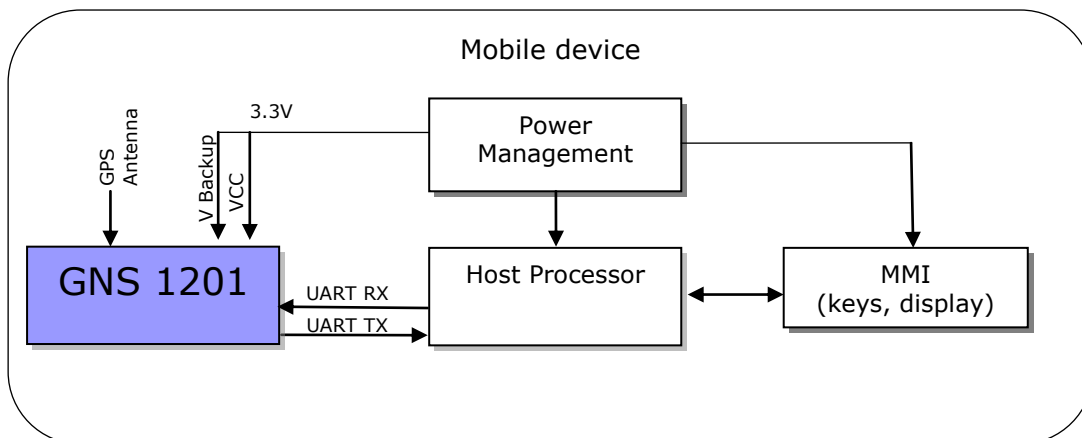

5 GPS characteristics

5.1 GPS characteristics					
Parameter	Min	Typ	Max	Unit	Note
general					
Frequency		1575.42		MHz	GPS L1
SV Numbers					GPS #1~32
DGPS					SBAS[WAAS,EGNOS, MSAS], RTCM
AGPS					Internal processing of predicted orbit data. Service available via ftp. 6hrs prediction interval
Output data frequency	1/10	1	10	1/sec	Configurable
Navigation&tracking sensitivity		-165	-167	dBm	
Acquisition sensitivity		-148		dBm	autonomous
TTFH hot start		1		sec	All SVs @-130dBm
TTFH warm start		33		sec	All SVs @-130dBm
TTFH autonomous cold start		34		sec	All SVs @-130dBm
Number of channels tracking		22			
Number of acquisition channels		66			
Dimension		11.5x13x2.1		mm	Tolerance is +/-0.2 mm
Weight		2		g	
Power consumption					
GPS ACTIVE (acquisition)		25*		mA	NMEA frequency = 1/sec*
GPS ACTIVE (tracking)		20*		mA	NMEA frequency = 1/sec*
Backup current @ 3V		7		µA	

*note: further power savings are possible using AlwaysLocate or periodical modes. Actual possible savings depend on use cases.

Accuracy					
Position error CEP50	-	3	-	m	Without aid
Position error CEP50	-	2.5	-	m	Using (SBAS)
Velocity error	-	0.1	-	m/s	Without aid
velocity error	-	0.05	-	m/s	Using (SBAS)

ITAR limits					
Operation altitude		-	18,000	m	
Operation velocity	-	-	515	m/s	
Operation acceleration	-	-	4	G	

6 DESIGN GUIDELINES

6.1 General

Although GNS1201 GPS module provides best performance at low power consumption, special care should be taken to provide clean signal and clean power supplies. A multi layer carrier board with solid power- and ground planes is recommended. Power lines should be blocked near to the module with low ESR capacitors.

Radiated noise from neighbour components may also reduce the performance of the module. Special care must be taken when designing the RF input tracks and antenna connection.

6.2 GPS antenna

GNS1201 contains all input circuitry needed to connect a passive antenna directly. If there is a long wire between GNS 1201 RF input and antenna, there should be an LNA (on the antenna side) to compensate for cable losses ("active" antenna).

The module is already prepared for connecting an active antenna. DC injection and DC decoupling from RF input is already onboard. Please connect a suitable power supply to pin3 (VANT). The power supply voltage should match the active antenna specified voltage. The current flowing from pin 3 to the antenna should be maximum 20mA (but typically much more lower to keep the total system power requirements low). In many cases, pin3 can be directly connected to Vcc (pin16). More information about connecting and implementing a GPS antenna to an application PCB, please refer to *GPS Antenna Design Guide.pdf*.

7 ELECTRICAL SPECIFICATION

7.1 Absolute Maximum Ratings

Parameter	Value	Unit
Supply voltage range: V _{cc}	-0.5 to 4.3	V
Backup voltage: V _{BACKUP}	-0.5 to 4.3	V
Input voltage to analog pins	-0.5 to 3.3	V
Input voltage to all other pins	-0.5 to V _{cc}	V
Operating ambient temperature range	-40 to +85	°C
Storage temperature range	-40 to +85	°C

7.2 Recommended Operating Conditions

Parameter	Min	Typ	Max	Unit	Note
V _{cc}	3.0	3.3	4.3	V	supply voltage
V _{BACKUP}	2.0	3.0	4.3	V	Backup voltage for RTC and memory retention, must be available during normal operation
High level output voltage V _{OH}	0.8 * V _{cc}		V _{cc}	V	
Low level output voltage V _{OL}	0		0.2*V _{DD}	V	
High-level input voltage V _{IH}	0.80* V _{cc}		V _{cc}	V	
Low-level input voltage V _{IL}	0		0.35* V _{cc}	V	
Operating temperature	-40		85	°C	Full specified sensitivity

7.3 GPS input characteristics

Parameter	Min	Typ	Max	Unit	Note
Maximum input level	0			dBm	
Input return loss		-6.1		dB	

8 DEVICE PINOUT DIAGRAM

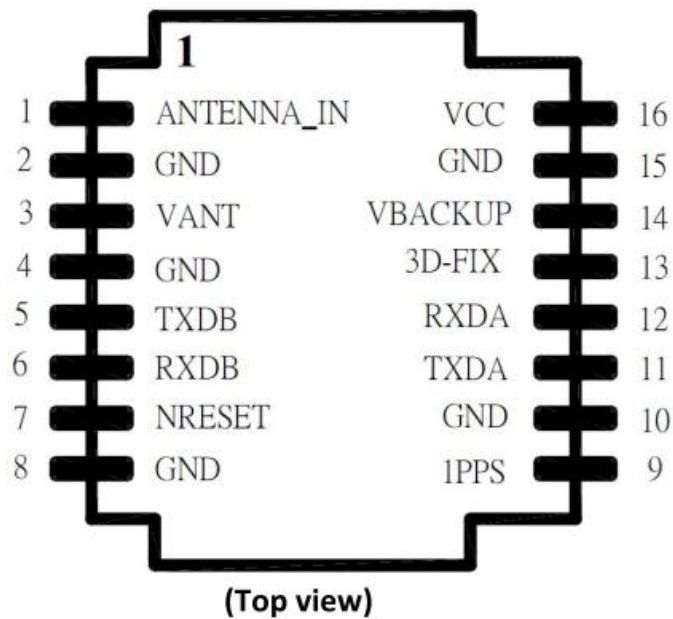

Pin	Name	I/O	Description & Note
1	Antenna_IN	I	Antenna Signal Input This is the GPS RF signal input pin, which can be connected to a passive antenna or an active antenna.
2	GND	p	Ground
3	VANT	P	External Antenna power input The power supply input for external active antenna. The input voltage should be kept from 2.5V to 5V.
4	GND	P	Ground
5	TXDB	O	Serial Data Output This is the UART-B transmitter of the module. It is used for customization by firmware. If not used, keep floating
6	RXDB	I	Serial Data Input for DGPS RTCM data streaming This pin receives DGPS data of RTCM protocol (TTL level), if not used keep floating.
7	NRESET	I	Reset Input, Low Active Low active, it causes the module to reset. If not used, keep floating.
8	GND	P	Ground
9	1PPS	O	1PPS Time Mark Output 2.8V CMOS Level This pin provides one pulse-per-second output from the module and synchronizes to GPS time. Keep floating if not used.
10	GND	P	Ground
11	TXDA	O	Serial Data Output A for NMEA output (TTL) This is the UART-A transmitter of the module. It outputs GPS information for application.
12	RXDA	I	Serial Data Input A for Firmware update (TTL) This is the UART-A receiver of the module. It is used to receive commands from system
13	3D_FIX	O	3D-Fix Indicator The 3D_FIX is assigned as a fix flag output. If not used, keep floating. Before 2D Fix The pin will continuously toggle with 0.5 Hz. output one second high-level and one-second low-level signal After 2D or 3D Fix The pin will continuously output low-level signal This pin may not connected to high-level at power-on sequence.
14	VBACKUP	P	Backup power input for RTC & navigation data keep This connects to the backup power of the GPS module. Power source (such as battery) connected to this pin will help the GPS chipset in keeping its internal RTC running when the main power source is turned off. The voltage should be kept between 2.0V~4.3V, Typical 3.0V. This pin must be connected for normal operation..
15	GND	P	Ground
16	VCC	P	Main DC power input The main DC power supply for the module. The voltage should be kept between from 3.0V to 4.3V. The ripple must be limited under 50mVpp (Typical: 3.3V).

(1) I = INPUT; O = OUTPUT; I/O = BIDIRECTIONAL; P = POWER PIN; ANA = ANALOG PIN.

9 NMEA DATA interface

GNS1201 provides NMEA (National Marine Electronics Association) 0183 compatible data.

A set of proprietary NMEA commands are available to send control messages to the module.

These commands are described in a separate document: *NMEAcommandInterface* .

For standard operation, no commands are needed; the module will start outputting NMEA sentences after power supply has been attached. GNS1201 will always start communication output with 9600 bit per second.

If non standard options are needed (f.e. other baud rate , other NMEA sequence) they can be programmed from host controller during runtime.

Important note : options set by using NMEA command interface are not persistent! They will be lost when power is removed. A backup supply at VBACKUP will be sufficient to keep them.

9.1 NMEA output sentences for GPS

NMEA output sentences	
Type	content
\$GPRMC	Recommended Minimum Navigation Information
\$GPGGA	Fix Data, Time, Position and fix related data for a GPS receiver
\$GPGLL	Geographic Position - Latitude/Longitude
\$GPVTG	Track made good and Ground speed
\$GPGSV	Satellites in view

9.2 NMEA command interface

GNS1201 NMEA command interface allows to control settings and the extended functions. The command interface specification is available in an extra document: *NMEACOMMANDINTERFACE manual*.

Two groups of commands are available:

Setting commands do modify the behavior of the module.

Note : modified settings will be valid as long as the module is powered through Vcc or VBACKUP. (f.e. : setting of a new baud rate). After removing Vcc and VBACKUP, all settings are reset to their default values

Action commands will perform the specified action one time after the command has been received. (f.e. : request for cold start)

Commands are always started with \$PTMK, directly followed by the command number 000..999.

Each command must be terminated by *<chksum> and a <CR><LF>.

The checksum calculation is simple, just XOR all the bytes between the \$ and the * (not including the delimiters themselves). Then use the hexadecimal ASCII format.

10 PHYSICAL DIMENSIONS

TOP VIEW

all units in mm, tolerance is $\pm 0.2\text{mm}$

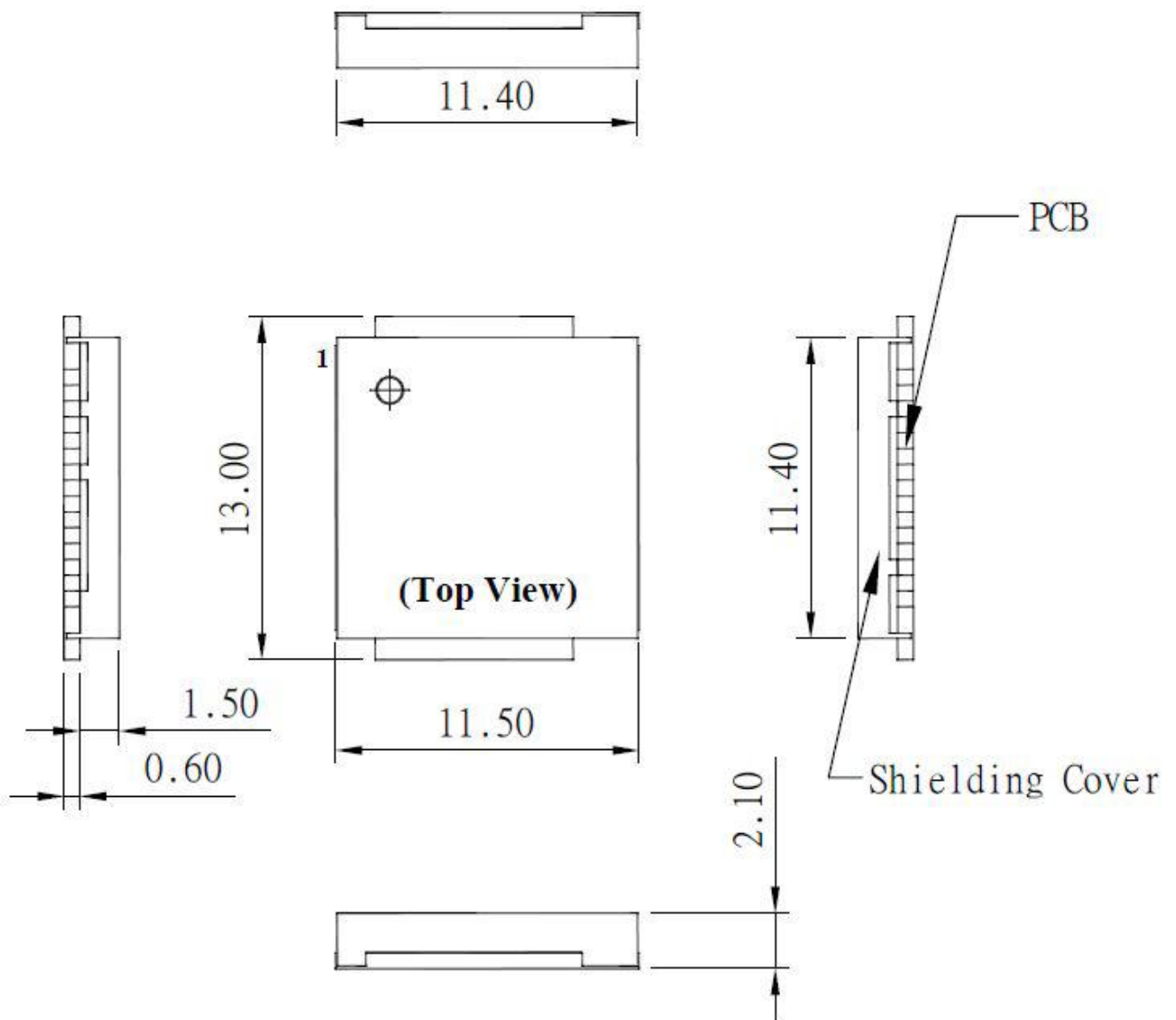

11 RECOMMENDED PAD LAYOUT

TOP VIEW
all units in mm

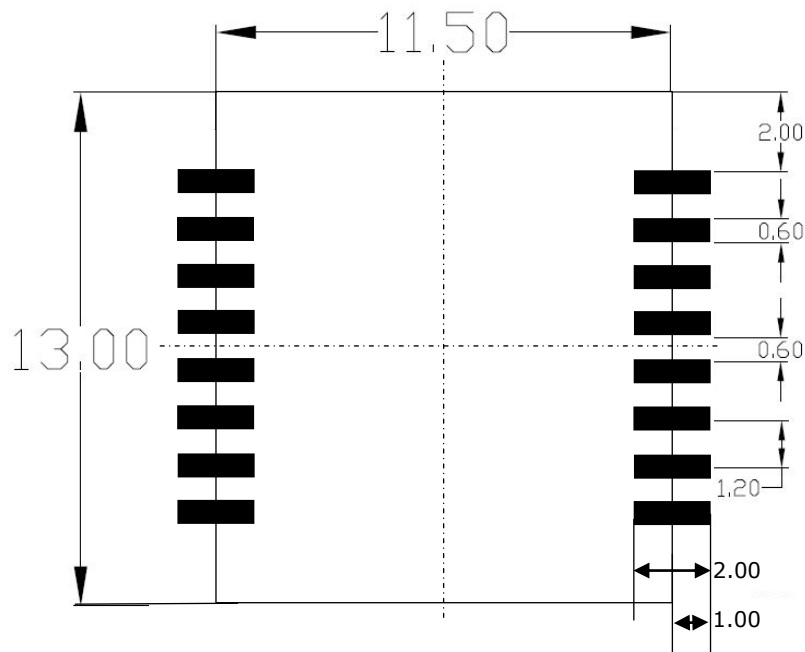

12 MATERIAL INFORMATION

Complies to ROHS standard
ROHS documentations are available on request
Contact surface: gold over nickel

13 RECOMMENDED SOLDERING REFLOW PROFILE

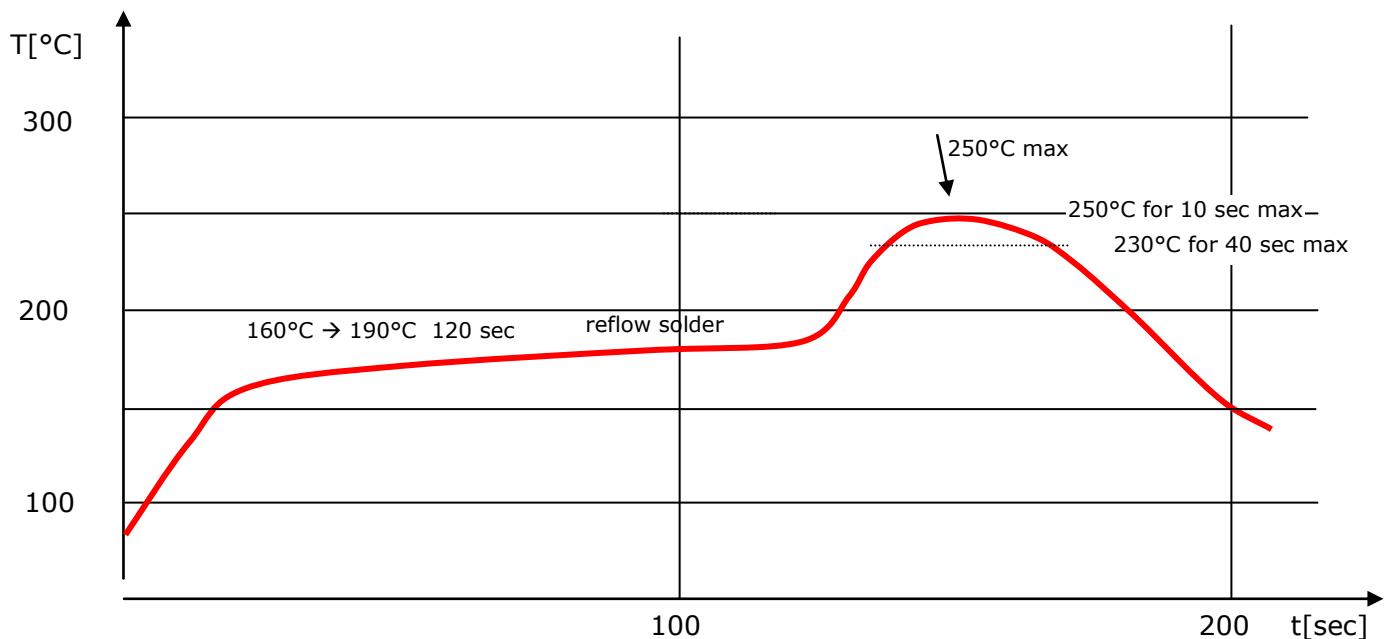

Notes:

1. GNS1201 should be soldered in upright soldering position. In case of head-over soldering, please prevent shielding / GNS1201 Module from falling down.
2. Do never exceed maximum peak temperature
3. Reflow cycles allowed : 1 time
4. Do not solder with Pb-Sn or other solder containing lead (Pb)
5. This device is not applicable for flow solder processing
6. This device is not applicable for solder iron process

14 TRAY PACKAGE INFORMATION

The GPS receivers are placed on a tray. The trays will be stacked and packed together. The trays are placed inside an antistatic bag.



15 ORDERING INFORMATION

Ordering information			
Type	Part#	label marking	Description
GNS1201	4037735104747	GNS 1201 1.2/2.5_432 1243 34512 ← Type HW/FW version ← datecode ← serial#	GNS1201 GPS Module

16 FCC AND CE COMPLIANCE

This product has passed FCC and CE tests successfully. The module emission and immunity has been proven to be compliant. However, applications using this module as a component must pass CE and/or FCC again in whole.

17 ENVIRONMENTAL INFORMATION

This product is free of environmental hazardous substances and complies with 2002/95/EC. (RoHS directive).



18 MOISTURE SENSITIVITY

This device must be prebaked before being put to reflow solder process. Disregarding may cause destructive effects like chip cracking, which leaves the device defective !

Shelf life	6 months , sealed
Possible prebake recommendations	12 hrs @ 60°C
Floor life (time from prebake to solder process)	<72 hrs

19 DOCUMENT REVISION HISTORY

Version	Date	Author	Description
V0.1	Oct 29 2012	P.Skaliks	Initial preliminary release
V0.11	Nov 5 2012	P.Skaliks	Standard baudrate modified, now 9600bd
V0.12	Nov 19 2012	P.Skaliks	Typo removed in featuralist: # of channels
V0.13	Dec 3 2012	M.Reiff	Tray package information added, Block diagram added, High altitude unlimiter feature added, RF input return loss defined, Related documents updated

20 RELATED DOCUMENTS

title	Description / file	Available from
<i>GPS Antenna Connection Design Guide</i>	Design Guide to implement an GPS antenna to an application PCB	www.forum.gns-gmbh.com
<i>NMEACommandInterface manual</i>	Detailed description of NMEA commands	www.forum.gns-gmbh.com
<i>GNS1201 StarterKit user manual</i>	User manual for the GNS1201 receiver based evaluation kit	www.forum.gns-gmbh.com

